

# Operator Manual

706/1006NT  
End -Wheel, No-Till Drill



*Read the operator manual entirely. When you see this symbol, the subsequent instructions and warnings are serious - follow without exception. Your life and the lives of others depend on it!*



38097

*Cover illustration may show optional equipment not supplied with standard unit.*

ORIGINAL INSTRUCTIONS



© Copyright 2021

Printed 2021-08-26

150-285M



## Machine Identification

Record your machine details in the log below. If you replace this manual, be sure to transfer this information to the new manual.

If you or the dealer have added options not originally ordered with the machine, or removed options that were originally ordered, the weights and measurements are no longer accurate for your machine. Update the record by adding the machine weight and measurements with the option(s) weight and measurements.

<b>Model Number</b>	
<b>Serial Number</b>	
<b>Machine Height</b>	
<b>Machine Length</b>	
<b>Machine Width</b>	
<b>Machine Weight</b>	
<b>Year of Construction</b>	
<b>Delivery Date</b>	
<b>First Operation</b>	
<b>Accessories</b>	<hr/> <hr/> <hr/>

## Dealer Contact Information

**Name:** \_\_\_\_\_

**Street:** \_\_\_\_\_

**City/State:** \_\_\_\_\_

**Telephone:** \_\_\_\_\_

**Email:** \_\_\_\_\_

**Dealer's Customer No.:** \_\_\_\_\_



**WARNING:** Cancer and Reproductive Harm - [www.P65Warnings.ca.gov](http://www.P65Warnings.ca.gov)



# Table of Contents

<b>Important Safety Information</b> .....	<b>1</b>	Storage.....	31
Safety Decals .....	5	Lubrication and Scheduled Maintenance .....	32
<b>Introduction</b> .....	<b>11</b>	<b>Options</b> .....	<b>36</b>
Description of Unit .....	11	<b>Appendix</b> .....	<b>39</b>
Intended Usage .....	11	Torque Values Chart .....	39
Models Covered .....	11	Tire Information .....	39
Document Family .....	11	Specifications and Capacities .....	40
Using This Manual.....	11	Hydraulic Schematic.....	40
Owner Assistance.....	12	Sprocket Configurations.....	41
Further Assistance.....	12	Seed Box.....	41
<b>Preparation and Setup</b> .....	<b>13</b>	Seed Box Agitator .....	41
Pre-start Checklist .....	13	Dual Seed Box .....	42
Hitching Tractor to Drill.....	13	Small Grass Seeds .....	42
Hitch Assembly.....	13	Native Grass .....	43
Hitch Height.....	14	Fertilizer .....	43
Hitching to Tractor.....	14	Fertilizer with Small Grass Seeds Box.....	44
Hydraulic Hookup .....	15		
Rephasing Cylinders .....	16		
Bleeding Hydraulics.....	17		
Leveling Drill.....	17		
<b>Operating Instructions</b> .....	<b>18</b>		
Pre-start Checklist .....	18		
Field Operation .....	18		
Acremeter Operation .....	19		
Opener Operation.....	19		
Transporting .....	20		
Cylinder Locks.....	20		
Unload Drill Box.....	20		
Clearance .....	20		
Road Rules.....	20		
Lock-out Hub.....	20		
Parking and Unhitching .....	21		
<b>Adjustments</b> .....	<b>22</b>		
Coulter Adjustments .....	22		
Coulter Depth Control.....	22		
Coulter Down Pressure .....	23		
Opener Adjustments.....	24		
Opener Seeding Depth.....	24		
Disc Blade Adjustments .....	25		
Gauge Wheel Idler Adjustment.....	26		
Drive Clutch .....	26		
Drive Train Operation .....	26		
Spring Tine Harrow.....	27		
<b>Troubleshooting</b> .....	<b>29</b>		
<b>Maintenance and Lubrication</b> .....	<b>31</b>		
Maintenance .....	31		

© Copyright 2006, 2009, 2010, 2011, 2012, 2013, 2014, 2015, 2016, 2017, 2018, 2019, 2021 All rights Reserved

Great Plains Manufacturing, Inc. provides this publication “as is” without warranty of any kind, either expressed or implied. While every precaution has been taken in the preparation of this manual, Great Plains Manufacturing, Inc. assumes no responsibility for errors or omissions. Neither is any liability assumed for damages resulting from the use of the information contained herein. Great Plains Manufacturing, Inc. reserves the right to revise and improve its products as it sees fit. This publication describes the state of this product at the time of its publication, and may not reflect the product in the future.

Trademarks of Great Plains Manufacturing, Inc. include: AccuShot, Max-Chisel, Row-Pro, Singulator Plus, Short Disk, Swath Command, Terra-Tine, Ultra-Chisel, and X-Press.

Registered Trademarks of Great Plains Manufacturing, Inc. include: Air-Pro, Clear-Shot, Discovator, Great Plains, Land Pride, MeterCone, Nutri-Pro, Seed-Lok, Solid Stand, Terra-Guard, Turbo-Chisel, Turbo-Chopper, Turbo-Max, Turbo-Till, Ultra-Till, Whirfilter, and Yield-Pro.

Brand and Product Names that appear and are owned by others are trademarks of their respective owners.

Printed in the United States of America



## Important Safety Information

### Look for Safety Symbol

The SAFETY ALERT SYMBOL indicates there is a potential hazard to personal safety involved and extra safety precaution must be taken. When you see this symbol, be alert and carefully read the message that follows it. In addition to design and configuration of equipment, hazard control and accident prevention are dependent upon the awareness, concern, prudence and proper training of personnel involved in the operation, transport, maintenance and storage of equipment.



### Be Aware of Signal Words

Signal words designate a degree or level of hazard seriousness.

DANGER, and the color Safety Red, indicate an imminent hazard which, if not avoided, will result in death or serious injury. This signal word is limited to the most extreme situations, typically for machine components that, for functional purposes, cannot be guarded.



WARNING, and the color Safety Orange, indicate a potential hazard which, if not avoided, could result in death or serious injury, and includes hazards that are exposed when guards are removed. It may also be used to alert against unsafe practices.



CAUTION, and the color Safety Yellow, indicate a potential hazard which, if not avoided, may result in minor or moderate injury. It may also be used to alert against unsafe practices.



### Prepare for Emergencies

- ▲ *Be prepared if a fire starts*
- ▲ *Keep a first aid kit and fire extinguisher handy.*
- ▲ *Keep emergency numbers for doctor, ambulance, hospital and fire department near phone.*



000  
112  
911  
999



### Be Familiar with Safety Decals

- ▲ *Read and understand "Safety Decals" on page 5, thoroughly.*
- ▲ *Read all instructions noted on the decals.*
- ▲ *Keep decals clean. Replace damaged, faded and illegible decals.*



## Wear Protective Equipment

- ▲ *Wear protective clothing and equipment.*
- ▲ *Wear clothing and equipment appropriate for the job. Avoid loose-fitting clothing.*
- ▲ *Because prolonged exposure to loud noise can cause hearing impairment or hearing loss, wear suitable hearing protection such as earmuffs or earplugs.*
- ▲ *Because operating equipment safely requires your full attention, avoid wearing entertainment headphones while operating machinery.*

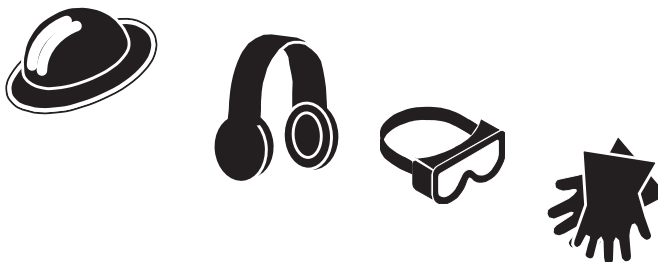

## Handle Chemicals Properly

Agricultural chemicals can be dangerous. Improper use can seriously injure persons, animals, plants, soil and property.

- ▲ *Do not use liquid seed treatments with the drill.*
- ▲ *Read and follow chemical manufacturer's instructions.*
- ▲ *Wear protective clothing.*
- ▲ *Handle all chemicals with care.*
- ▲ *Avoid inhaling smoke from any type of chemical fire.*
- ▲ *Never drain, rinse or wash dispensers within 100 feet (30m) of a freshwater source, nor at a car wash.*
- ▲ *Store or dispose of unused chemicals as specified by chemical manufacturer.*
- ▲ *Dispose of empty chemical containers properly. Laws generally require power rinsing or rinsing three times, followed by perforation of the container to prevent re-use.*



## Avoid High Pressure Fluids

Escaping fluid under pressure can penetrate the skin, causing serious injury.

- ▲ *Avoid the hazard by relieving pressure before disconnecting hydraulic lines.*
- ▲ *Use a piece of paper or cardboard, NOT BODY PARTS, to check for suspected leaks.*
- ▲ *Wear protective gloves and safety glasses or goggles when working with hydraulic systems.*
- ▲ *If an accident occurs, seek immediate medical attention from a physician familiar with this type of injury.*

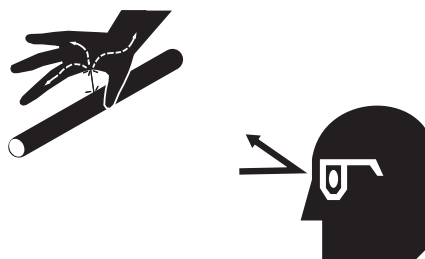

## Keep Riders Off Machinery

Riders obstruct the operator's view. Riders could be struck by foreign objects or thrown from the machine.

- ▲ *Never allow children to operate equipment.*
- ▲ *Keep all bystanders away from machine during operation.*



## Use Safety Lights and Devices

Slow-moving tractors and towed implements can create a hazard when driven on public roads. They are difficult to see, especially at night.

- ▲ Use flashing warning lights and turn signals whenever driving on public roads.
- ▲ Use lights and devices provided with implement



## Transport Machinery Safely

Maximum transport speed for implement is 20 mph (30 km/h). Some rough terrains require a slower speed. Sudden braking can cause a towed load to swerve and upset.

- ▲ Do not exceed 20 mph (30 km/h). Never travel at a speed which does not allow adequate control of steering and stopping. Reduce speed if drill is not equipped with brakes.
- ▲ Comply with state and local laws.
- ▲ Carry reflectors or flags to mark drill in case of breakdown on the road.
- ▲ Semi-mounted and 3-point implements reduce weight on steering tires. Verify that tractor is correctly ballasted. Watch for signs of poor steering traction.

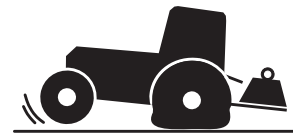

## Tires Not a Step

Do not use gauge wheel or lift-assist tires as steps. A tire could spin underfoot, resulting in a fall onto the implement or ground, possibly causing serious injury.

- ▲ The gauge wheel tires can be in poor ground contact at any time, even with the drill lowered in the field. They can appear to be in ground contact, and spin easily, in multiple conditions.
- ▲ The lift-assist tires can be in poor ground contact, or out of ground contact, whenever the drill is lowered.



## Shutdown and Storage

- ▲ Park on level ground.
- ▲ Unhitch and store the drill in an area where children normally do not play.

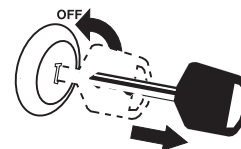

## Tire Safety

Tire changing can be dangerous and should be performed by trained personnel using correct tools and equipment.

- ▲ When inflating tires, use a clip-on chuck and extension hose long enough for you to stand to one side—not in front of or over tire assembly. Use a safety cage if available.
- ▲ When removing and installing wheels, use wheel-handling equipment adequate for weight involved.



## Practice Safe Maintenance

- ▲ *Understand procedure before doing work. Use proper tools and equipment. Refer to this manual.*
- ▲ *Work in a clean, dry area.*
- ▲ *Lower the drill, put tractor in park, turn off engine, and remove key before performing maintenance. If work must be performed with implement raised, use blocks or jackstands rated for the drill weight.*
- ▲ *Make sure all moving parts have stopped and all system pressure is relieved.*
- ▲ *Allow drill to cool completely.*
- ▲ *Disconnect battery ground cable (-) before servicing or adjusting electrical systems.*
- ▲ *Welding: Disconnect battery ground. Avoid fumes from heated paint.*
- ▲ *Inspect all parts. Make sure parts are in good condition and installed properly.*
- ▲ *Remove buildup of grease, oil or debris.*
- ▲ *Remove all tools and unused parts from drill before operation.*

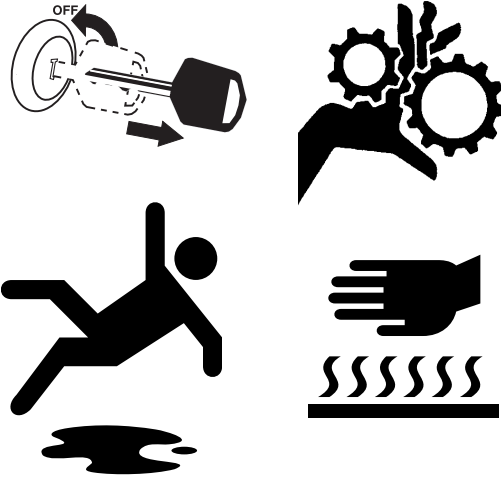

## Safety At All Times

Thoroughly read and understand the instructions in this manual before operation. Read all instructions noted on the safety decals.

- ▲ *Be familiar with all drill functions.*
- ▲ *Operate machinery from the driver's seat only.*
- ▲ *Do not leave drill unattended with tractor engine running.*
- ▲ *Do not stand between the moving tractor and drill during hitching.*
- ▲ *Keep hands, feet and clothing away from power-driven parts.*
- ▲ *Wear snug-fitting clothing to avoid entanglement with moving parts.*
- ▲ *Make sure all persons are clear of working area.*

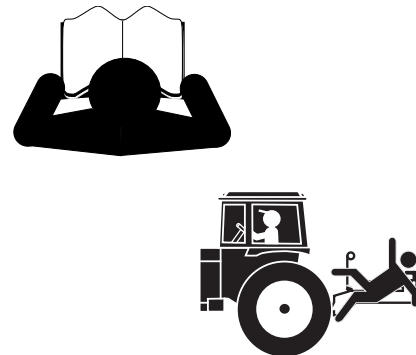



## Safety Decals

### Safety Reflectors and Decals

Your implement comes equipped with all lights, safety reflectors and decals in place. They were designed to help you safely operate your implement.

- ▲ *Read and follow decal directions.*
- ▲ *Keep lights in operating condition.*
- ▲ *Keep all safety decals clean and legible.*
- ▲ *Replace all damaged or missing decals. Order new decals from your dealer. Refer to this section for proper decal placement.*
- ▲ *When ordering new parts or components, also request corresponding safety decals.*

### Reflector: Slow Moving Vehicle (SMV)

818-055C



On rear of walkboard;  
1 total

See “**Transporting**” on page 19.

### To install new decals:

1. Clean the area on which the decal is to be placed.
1. Peel backing from decal. Press firmly on surface, being careful not to cause air bubbles under decal.

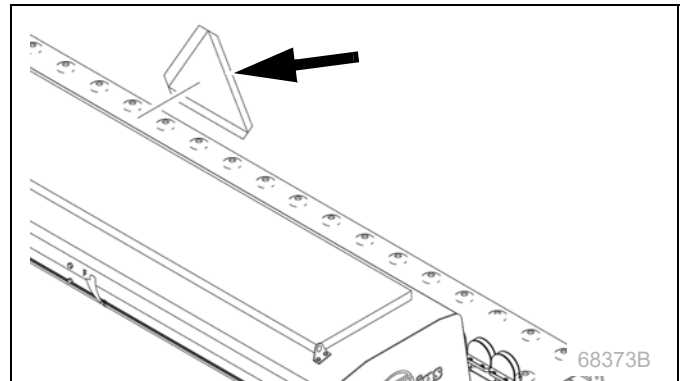

### Reflectors: Red (706NT only)

838-266C



On rear face of walkboard at each end;  
2 total

See “**Transporting**” on page 19.

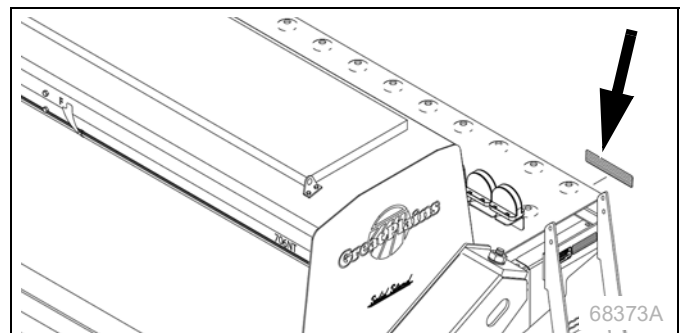

### Reflectors: Red (1006NT S/N 4328XX-)

838-266C



On rear face of walkboard, outside daytime reflectors;  
2 total

See “**Transporting**” on page 19.

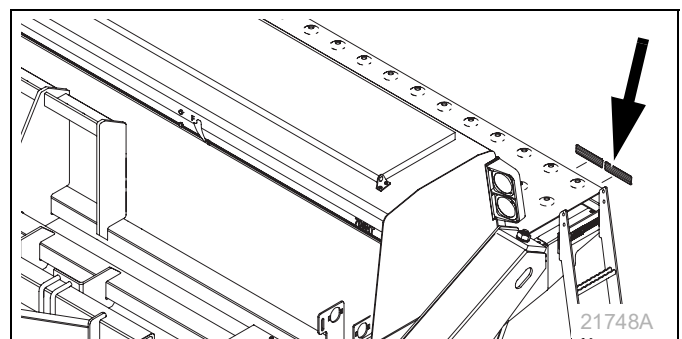

**Reflectors: Red (1006NT S/N 4329XX+)**

838-266C



On rear face of light bracket, both ends;  
2 total

See “**Transporting**” on page 19.

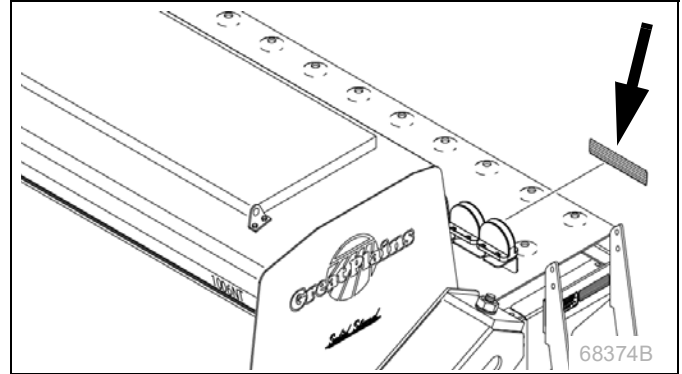
**Reflectors: Amber**

838-265C



On side frames at walkboard ends,  
on front face of lower front tool bars, outside ends;  
4 total

See “**Transporting**” on page 19.

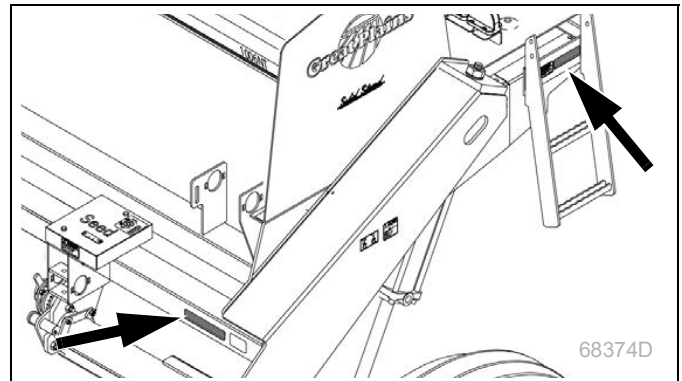
**Reflectors: Daytime (1006NT S/N 4328XX-)**

838-267C



On rear face of walkboard, inside red reflectors;  
2 total

See “**Transporting**” on page 19.

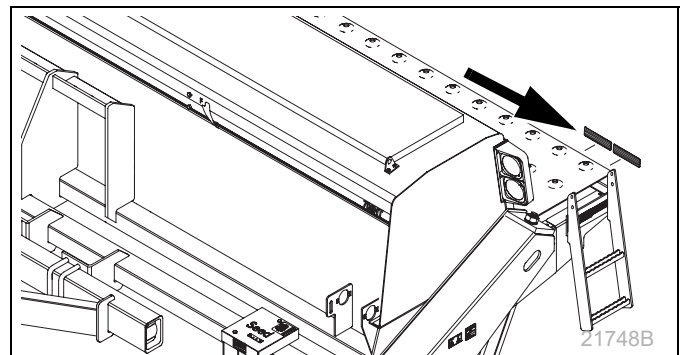
**Reflectors: Daytime (1006NT S/N 4329XX+)**

838-267C



On rear face of walkboard at each end;  
2 total

See “**Transporting**” on page 19.

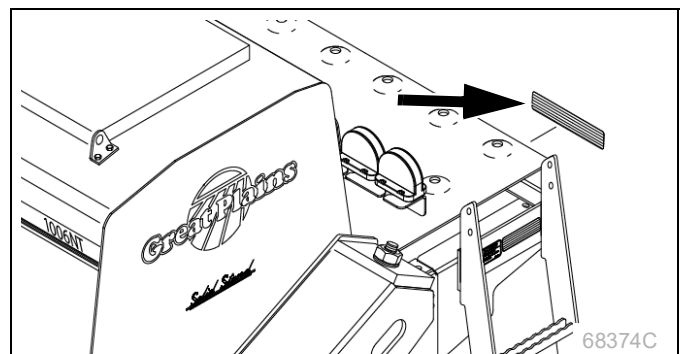

**Caution: Operation of Machine**

818-587C



On top of tongue;  
1 total

**Caution: General**

818-719C

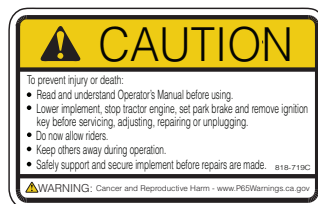

On top of tongue;  
1 total

See "Important Safety Information" on page 1.

**Caution: Tires Not A Step**

818-398C



One each on outer frame weldments, one on right-hand end of walkboard;  
3 total

See "Tires Not a Step" on page 3.

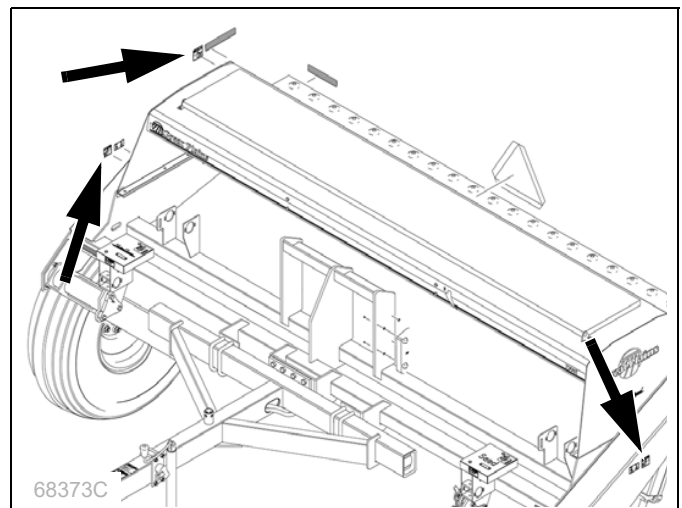
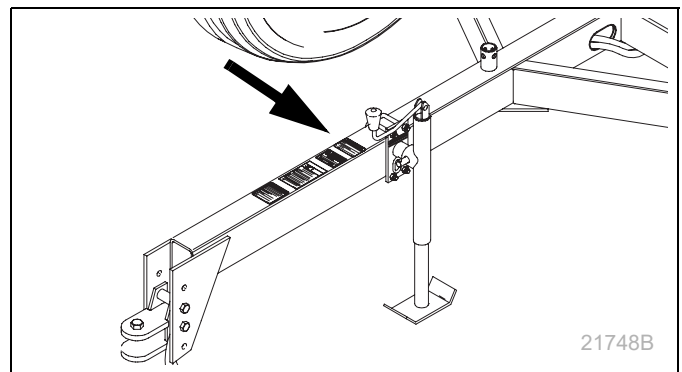
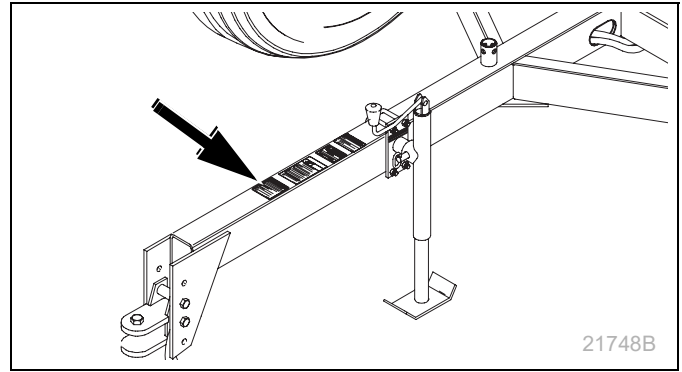

**Caution: Moving Chain**

818-518C

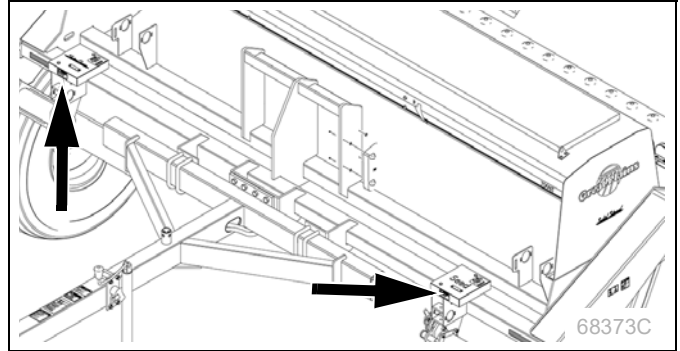

Dual Seed: On outside of box end wall, under both covers;  
2 total

**Caution: Moving Chain (Option)**

818-518C

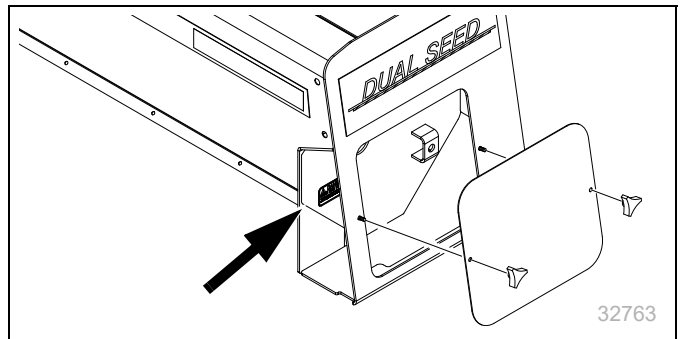

Dual Seed: On outside of box end wall, under both covers;  
2 total

**Caution: Moving Chain (Option)**

818-518C

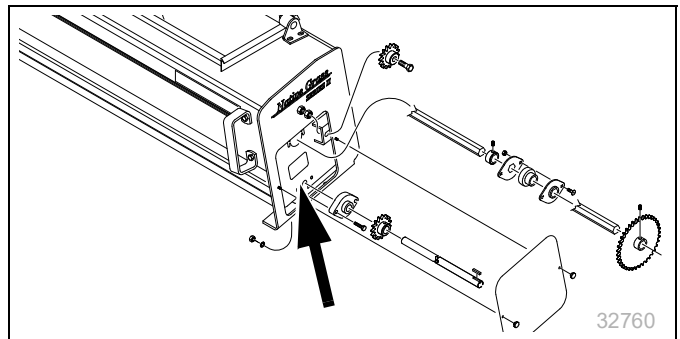

Native Grass: On outside of box end wall, under both covers;  
2 total

**Caution: Moving Chain (Option)**

818-518C



Small Seeds: On chain guard of Small Seeds option;  
1 total

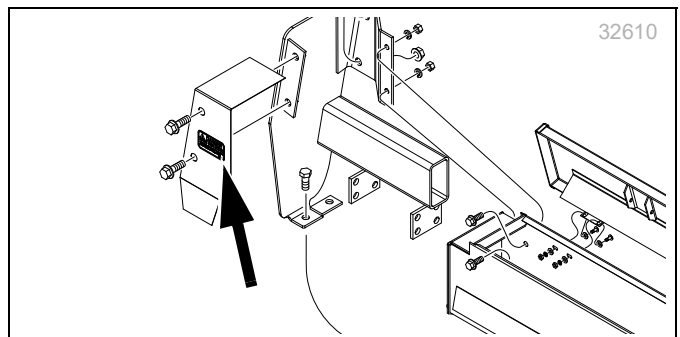

**Caution: High Pressure Hazard**

838-556C

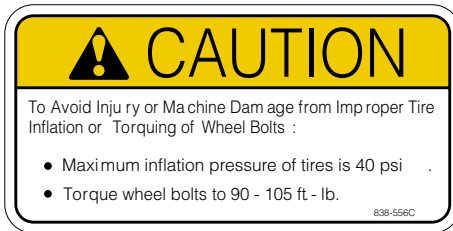

On each wheel;  
2 total

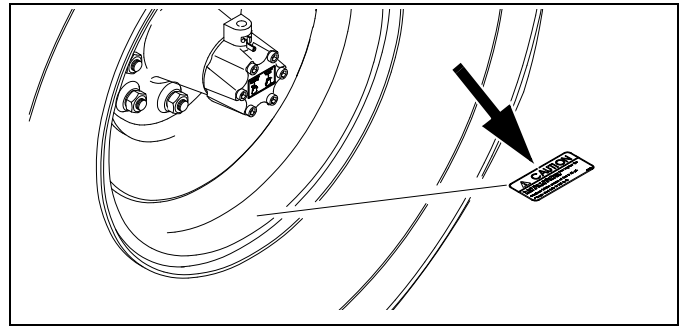
**Warning: High Pressure Fluid**

818-437C

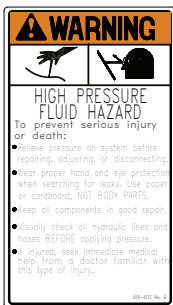

On top of tongue;  
1 total

See “Hitching Tractor to Drill” on page 13.

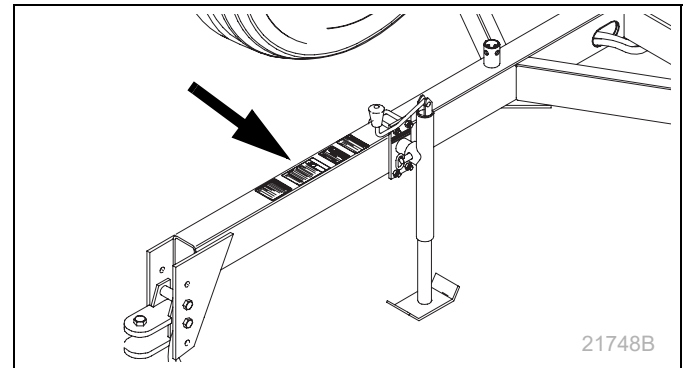
**Warning: Speed**

818-337C



On top of tongue;  
1 total

See “Transporting” on page 19.

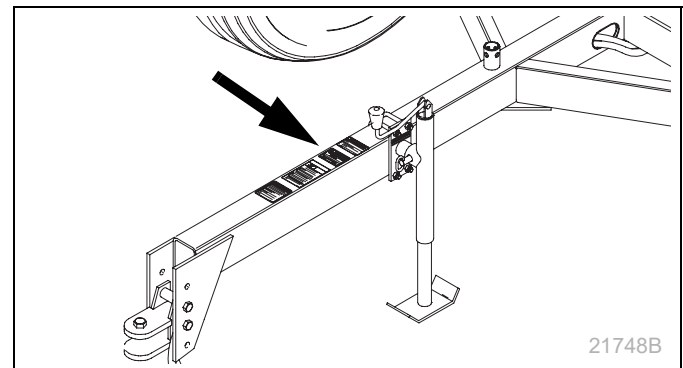
**Warning: Jack Angle**

858-895C



On face of jack mount;  
1 total

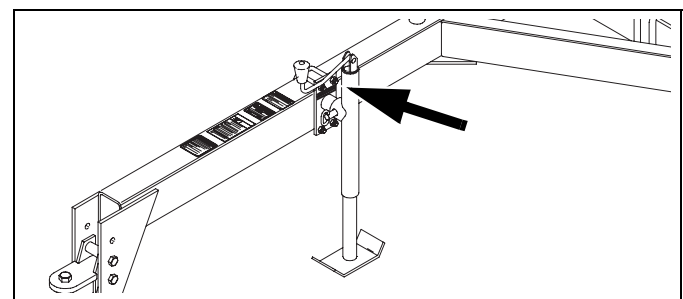

**Warning: Falling Hazard**

838-102C



On left-hand side of frame at ladder;  
1 total

See “**Field Operation**” on page 18.

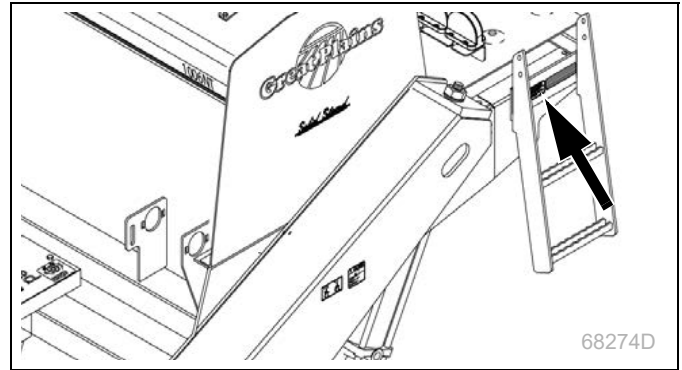
**Warning: Hand Crush (Option)**

838-611C



Dual Seed: Under lid;  
1 total

See “**Hitching Tractor to Drill**” on page 13.

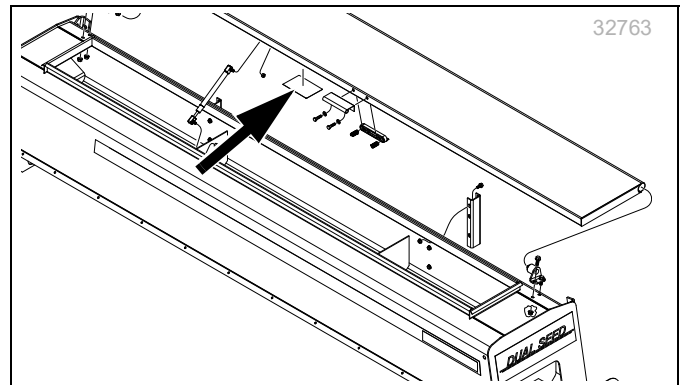
**Warning: Hand Crush (Option)**

838-611C



Native Grass: Under lid;  
2 total

See “**Hitching Tractor to Drill**” on page 13.

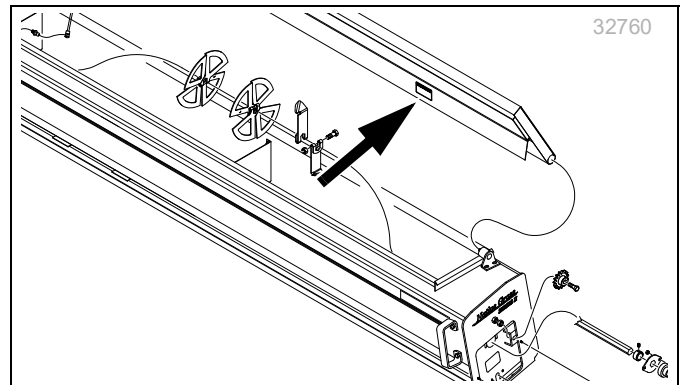
**Danger: Possible Chemical Hazard**

838-467C



Under lid of Small Seeds box;  
1 total

See “**Field Operation**” on page 18.

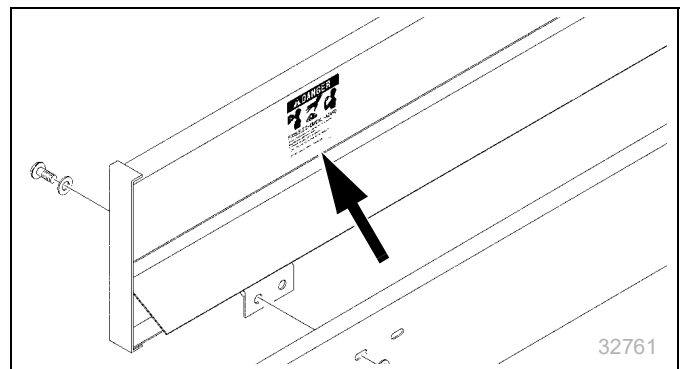





# Introduction

Great Plains welcomes you to its growing family of new product owners. Your drill has been designed with care and built by skilled workers using quality materials. Proper setup, maintenance, and safe operating practices will help you get years of satisfactory use from the machine.

## Description of Unit

The 706/1006NT is a grain drill of end wheel design which couples spring mounted coulter to achieve no-till drilling capabilities. The end wheel design keeps the ground-working components in line with the end wheels for accurate coulter depth and seed placement over uneven terrain and allows the unit to follow filed curves without side-loading the openers.

## Intended Usage

Use this drill to primarily for no-till drilling. It can easily be adapted for conventional drilling applications.

## Models Covered

This manual applies to compact drill model:

706NT-1075	10-row 7.5-inch (19.1 cm)
706NT-1107	11-row 7-inch (17.8 cm)
706NT-8006	10-row 8-inch (20.3 cm)
1006NT-1408	14-row 8-inch (20.3 cm)
1006NT-1575	15-row 7.5-inch (19.1 cm)
1006NT-1607	16-row 7-inch (17.8 cm)

## Document Family

150-285M	Operator Manual (this document)
150-285P	706/1006NT Parts Manual
150-285B	Seed Rate Manual

## NOTICE

Refer to 706/1006NT End-Wheel, No-Till Drill seed rate book for seed rate charts, calibration instructions, and setting seed rate instructions.

## Using This Manual

This manual familiarizes you with safety, assembly, operation, adjustments, troubleshooting, and maintenance. Read this manual and follow the recommendations to help ensure safe and efficient operation.

The information in this manual is current at printing. Some parts may change to assure top performance.



Figure 1  
706/1006NT Drill

38097

## Definitions

The following terms are used throughout this manual.

## NOTICE

*A crucial point of information related to the current topic. Read and follow the directions to remain safe, avoid serious damage to equipment, and ensure desired field results.*



### NOTE:

Useful information related to the current topic.

Right-hand and left-hand as used in this manual are determined by facing the direction the machine will travel while in use unless otherwise stated. An orientation rose in some line art illustrations shows the directions of: Up, Back, Left, Down, Front, Right.

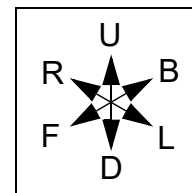

## Owner Assistance

If you need customer service or repair parts, contact a dealer. They have trained personnel, repair parts and equipment specially designed for products.

### **Refer to Figure 2**

Your machine's parts were specially designed and should only be replaced with parts. Always use the serial and model number when ordering parts from your dealer. The serial-number plate is located on the top front cross-tube, left of the left gauge wheel mount.

Record your drill model and serial number here for quick reference:

Model Number: \_\_\_\_\_

Serial Number: \_\_\_\_\_

## Further Assistance

Great Plains Manufacturing, Inc. and your Great Plains dealer want you to be satisfied with your new drill. If for any reason you do not understand any part of this manual or are otherwise dissatisfied, please take the following actions first:

1. Discuss the matter with your dealership service manager. Make sure they are aware of any problems so they can assist you.
2. If you are still unsatisfied, seek out the owner or general manager of the dealership.

If your dealer is unable to resolve the problem or the issue is parts related, please contact:

**Great Plains Service Department**  
**1525 E. North St.**  
**P.O. Box 5060**  
**Salina, KS 67402-5060**

Or go to [www.greatplainsag.com](http://www.greatplainsag.com) and follow the contact information at the bottom of your screen for our service department.

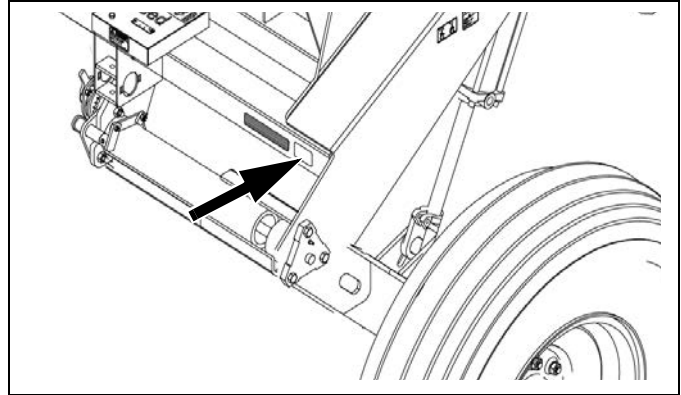

Figure 2  
Serial Number Location

68374D





## Preparation and Setup

This section will help you prepare your tractor and drill for use. Before going to the field, you must hitch a tractor to the drill, hook up hydraulics and check that hydraulics have been bled.

### Pre-start Checklist

- Read and understand “**Important Safety Information**” on page 1.
- Check that all working parts are moving freely, bolts are tight, and cotter pins are spread.
- Check that all grease fittings are in place and lubricated. See “**Lubrication and Scheduled Maintenance**” on page 32.
- Check that all safety decals and reflectors are correctly located and legible. Replace if damaged. See “**Safety Decals**” on page 5.
- Inflate tires to pressure recommended and tighten wheel bolts as specified. See “**Appendix**” on page 39.

### Hitching Tractor to Drill

#### **⚠ DANGER**

*You may be severely injured or killed by being crushed between the tractor and drill. Do not stand or place any part of your body between drill and moving tractor. Stop tractor engine and set park brake before installing the hitch pin.*

### Hitch Assembly

Refer to Figure 3

1. Insert upper hitch plate ① into clevis hitch ② with a spacer tube ③ on each side of ball swivel.
2. Bolt in place with 1 x 5 1/2 inch bolt ④, flat washer ⑤ and nylock nut ⑥.

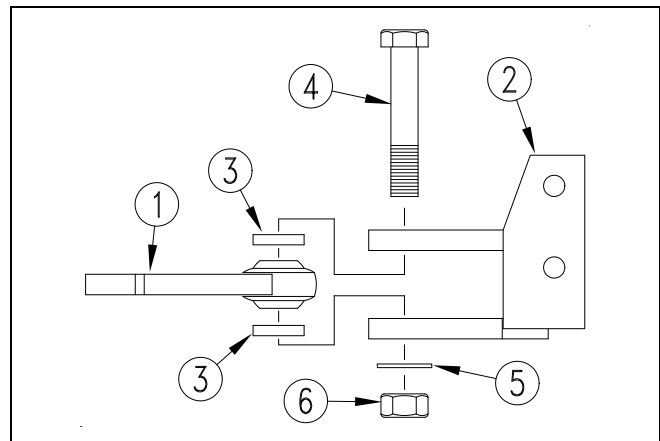

Figure 3  
Hitch Assembly

13939

## Hitch Height

### Refer to Figure 4

For proper field operation, drill tongue should run level in field position.

- With drill in field position, adjust tongue jack to level tongue.
- Measure tractor drawbar height to determine proper hitch height on drill.
- Attach hitch to tongue with two  $\frac{3}{4}$  x 6 inch bolts ①, lock washers ② and nuts ③.

#### NOTE:

Mounting holes in drill hitch are offset so hitch can be turned over and attached in three different positions, giving six different hitch heights.

#### NOTE:

When hitching drill to a different tractor, check for a difference in draw-bar heights. If heights are different, readjust accordingly.

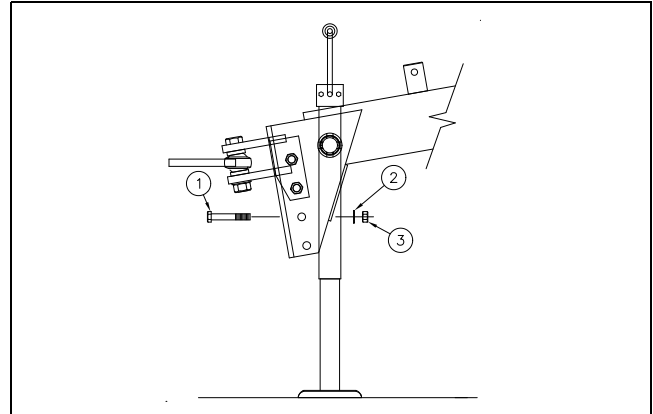

Figure 4  
Hitch Height

21703

## Hitching to Tractor

### Refer to Figure 5

- Back tractor to drill. Using the screw jack, adjust drill tongue to get drawbar under upper hitch plate ①.
- Align rear hole in upper hitch plate with large hole in drawbar. Place lower hitch plate ④ under drawbar and attach to upper hitch plate with two  $\frac{5}{8}$  x 4 inch bolts ⑤, flat washers ⑥ and nylock nuts ⑦.
- Bolt top upper hitch plate through hole in drawbar to lower hitch plate with 1 x  $5\frac{1}{2}$  inch bolt ⑧, USS flat washer ③ and nylock nut ②.
- Securely attach safety chain to drill hitch with a  $\frac{3}{4}$  x  $2\frac{1}{4}$  inch bolt ⑩, safety washer ⑪, lock washer ⑫ and nut ⑬. Then attach chain to tractor drawbar.

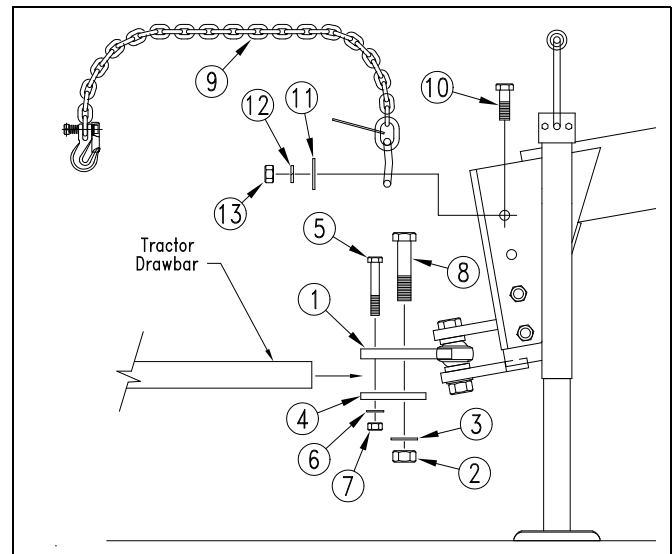

Figure 5  
Tractor Hitch

13944

**Refer to Figure 6**

5. Store jack on top of tongue.

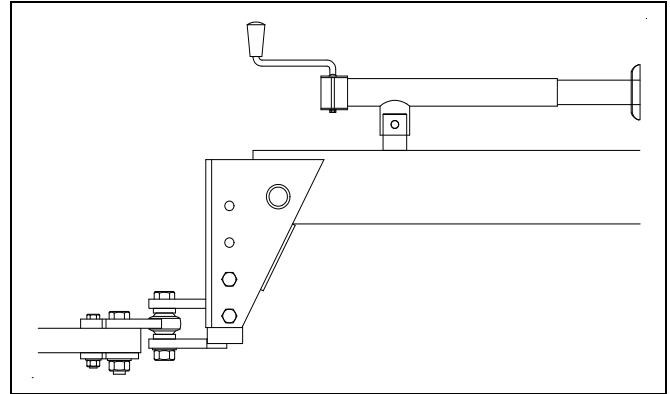
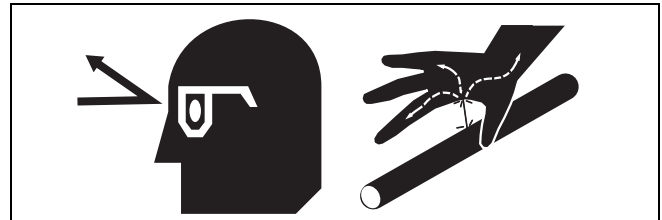

Figure 6  
Jack Storage Position

13940

**Hydraulic Hookup**
**WARNING**
**High Pressure Fluid Hazard:**

Relieve pressure before disconnecting hydraulic lines. Escaping fluid under pressure can have sufficient pressure to penetrate the skin causing serious injury. Use a piece of paper or cardboard, **NOT BODY PARTS**, to check for leaks. Wear protective gloves and safety glasses or goggles when working with hydraulic systems. If an accident occurs, seek immediate medical attention from a physician familiar with this type of injury.

**Refer to Figure 7**

Great Plains hydraulic hose connectors have color coded handle grips to help you hookup hoses to your tractor outlets. Hoses that go to the same remote valve are marked with the same color.

Color	Hydraulic Function
Blue	Transport Lift Cylinders
Orange	Marker Cylinders

To distinguish hoses on the same hydraulic circuit, refer to the symbol molded into the handle grip. Hoses with an extended-cylinder symbol feed cylinder base ends. Hoses with a retracted-cylinder symbol feed cylinder rod ends.

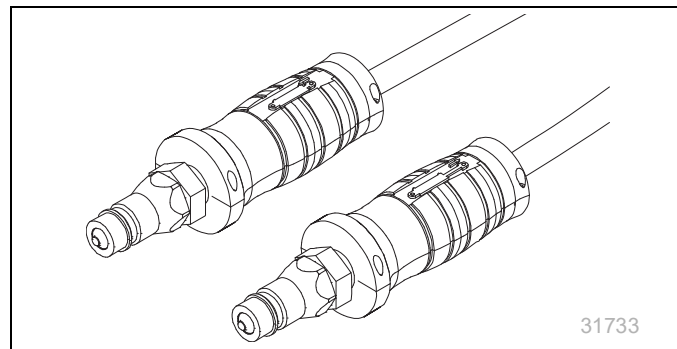

Figure 7  
Color-Coded Hose Grips

31733

## Route Hose Bundle

Refer to *Figure 8*

1. Route the hose bundle ① under the rear cross-tube of the tongue, into the access hole ②, and out the front of the tongue tube near the hitch.
2. Remove the hose plugs and color-coded hose grips before attempting to route the hydraulic hoses through the tongue.
3. Once hydraulic hoses are routed through the tongue, attach color-coded grips to the correct hydraulic hose. Retract grip and hose go to the rod end of the cylinder. Extend grip and hose go to the base end of the cylinder.

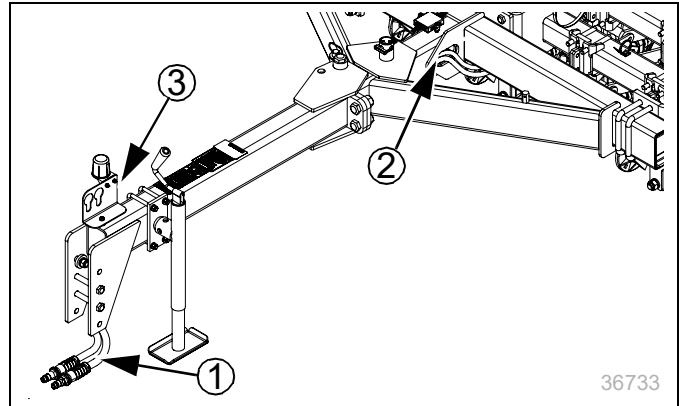

Figure 8  
Route Hoses and Harness

## Rephasing Cylinders

The lift cylinders may, after a period of time, get out of time or phase. The effects of this can be seen when one side of the drill is running too low or too high because its lift cylinder is either over extended or not retracted compared to the other lift cylinder.

To rephase the cylinders, raise drill completely and hold tractor hydraulic lever on for a few seconds to give cylinders time to rephase.

Each time drill is raised out of ground momentarily reverse hydraulic lever immediately after rephasing to allow cylinders to retract about  $\frac{1}{2}$  inch. This will help in maintaining a level drill.

### NOTE:

Understand that having cylinders become gradually out of time is different than having air trapped in the system from improper bleeding. Each condition is corrected differently.

## Bleeding Hydraulics

The drill lifting system is equipped with rephasing type hydraulic cylinders that require a special procedure for bleeding air from the hydraulic circuits. Read and follow this procedure carefully. Rephasing type cylinders will not function properly with air in hydraulic circuit.

1. Check hydraulic fluid in tractor reservoir and fill reservoir to proper level. Drill-system capacity is about 1 gallon. Add fluid to system as needed. A low reservoir level may draw air back into the system, causing jerky or uneven cylinder movements.
2. With drill attached to tractor, jack drill up and support frame at ends near gauge wheels.
3. With drill raised and supported, unpin cylinders from gauge wheel arms and frame. Turn cylinders "rod end up". Wire or otherwise safely support rod ends higher than base ends.
4. With tractor engine idling, engage tractor hydraulics to extend cylinder rods. When cylinder rods are completely extended, hold remote lever on for one minute.
5. Retract cylinders. Extend cylinders again and hold remote lever on for one more minute. Repeat this step two more times to completely bleed system.
6. Pin cylinders to drill frame and gauge wheel arm with transport cylinder locks in place. If any air still is trapped in either cylinder, the cylinder will have a spongy, erratic movement and drill will not raise evenly. If necessary, repeat bleeding process.
7. Refill tractor hydraulic fluid reservoir to its proper level.

### NOTE:

After the drill is raised, a slight settling will occur due to the action of the rephasing cylinders.

## Leveling Drill

### Refer to Figure 9

1. Loosen locknuts ② and adjust cylinder eyebolts ①. The eye bolts are factory pre-set at  $4 \frac{3}{4}$ " of thread above mounting plate.
2. Raise drill with hydraulics until openers and coulters are 1 to 2 inches off the ground.
3. Measure height of coulters from ground on both ends of drill.
4. Adjust eyebolt to level drill from end to end.
5. Tighten nuts on eyebolts when drill is level.

### CAUTION

Do not exceed 5 in (127 mm) of thread above mounting plate. This could lead to hydraulic cylinder damage.

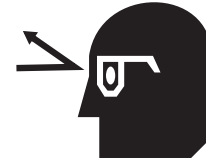

### NOTE:

In order to prevent trapped air pockets, rod end must be higher than any other part of cylinder during bleeding operation.

### WARNING

Escaping fluid under pressure can have sufficient pressure to penetrate the skin. Check all hydraulic lines and fittings before applying pressure. Fluid escaping from a very small hole can be almost invisible. Use paper or cardboard, not body parts, and wear heavy gloves to check for suspected leaks. If injured, seek medical assistance from a doctor that is familiar with this type of injury. Foreign fluids in the tissue must be surgically removed within a few hours or gangrene will result. Check that tractor hydraulic reservoir is full.

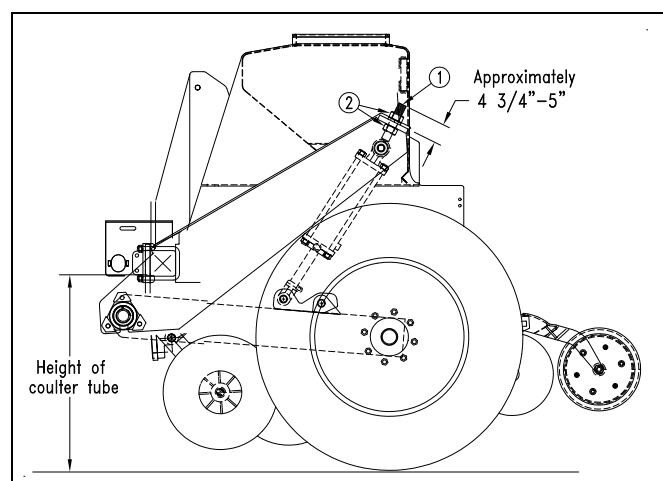

Figure 9  
Leveling Drill

20704



# Operating Instructions

This section covers general operating procedures. Experience, machine familiarity and the following information will lead to efficient operation and good working habits. Always operate farm machinery with safety in mind.

## Pre-start Checklist

1. Carefully read “**Important Safety Information**” starting on page 1.
2. Lubricate drill as indicated under “**Lubrication and Scheduled Maintenance**” on page 32.
3. Check all tires for proper inflation. See “**Appendix**” on page 39.
4. Check all bolts, pins and fasteners. Torque as shown in “**Appendix**” on page 39.
5. Check drill for worn or damaged parts. Repair or replace parts before going to the field.
6. Check hydraulic hoses, fittings and cylinders for leaks. Repair or replace before going to the field.
7. Rotate both gauge wheels to make sure the drive and meters are working properly and free from foreign material.

## Field Operation

1. Hitch drill to a suitable tractor.
2. Set seed population as explained in the seed rate book.
3. Load box with clean seed.
4. Raise drill. Rotate gauge wheel. Check that feed cups, seed tubes and drives are working properly and free from foreign material by looking for seed flow under each opener.
5. Record acremeter readout. Subtract initial reading from later readings to determine acres drilled.
6. Pull forward, lower drill and begin seeding.
7. Always lift drill out of the ground when turning at row ends and for other short-radius turns. Seeding will stop automatically as drill is raised.

### **⚠ WARNING**

*Escaping fluid under pressure can have sufficient pressure to penetrate the skin. Check all hydraulic lines and fittings before applying pressure. Fluid escaping from a very small hole can be almost invisible. Use paper or cardboard, not body parts, and wear heavy gloves to check for suspected leaks. If injured, seek medical assistance from a doctor that is familiar with this type of injury. Foreign fluids in the tissue must be surgically removed within a few hours or gangrene will result.*

### **⚠ DANGER**

*Watch your step when walking on drill ladder and walkboard. Falling from drill could cause severe injury or death.*

### **⚠ DANGER**

*You may be severely injured or killed by being crushed between the tractor and drill. Do not stand or place any part of your body between drill and moving tractor. Stop tractor engine and set park brake before installing pins.*

## Acremeter Operation

The acremeter<sup>1</sup> counts shaft rotations whenever the shaft is rotating - normally this is only with the drill lowered and in motion. The meter is programmed to display rotations as acres or hectares, when using all rows, factory-specified tires and tire inflations.

### NOTE:

Unusual conditions and/or non-standard row spacings can cause the acremeter tally to vary somewhat from actual acres planted.

### Refer to Figure 10

Acremeters supplied with units have varied over time. For operational details (modes, resets, calibration), see the manual supplied with the acremeter:

Meter Style and Manual	
① 194-074M	③ 152-314M
② 152-325M	④ 194-209M

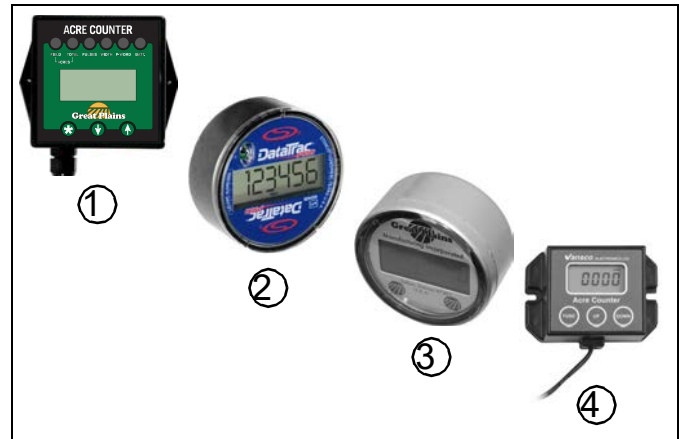

Figure 10  
Acremeters

34776  
34937  
27378  
36275

## Opener Operation

### CAUTION

*Never back up with openers in the ground. To do so may cause damage or opener plugging.*

For information on opener adjustments, see page 24. For more information on troubleshooting opener problems, see “**Troubleshooting**” on page 29.

## Transporting

### WARNING

*Towing the drill at high speeds or with a vehicle that is not*

*heavy enough could lead to loss of vehicle control. Loss of vehicle control could lead to serious road accidents, injury and death. To reduce the hazard, do not exceed 20 mph*

1. An electronic acremeter is available as an upgrade for older drills having a mechanical acremeter.



(30 km/h). Check that your tractor has enough ballast to handle the weight of the drill. Refer to your tractor operator's manual for ballast requirements.

injury or death. To prevent an accident, always install cylinder locks before transporting drill.

## **CAUTION**

Failure of hydraulic cylinders during transport will cause drill to drop suddenly, which could lead to serious road accidents,

Before transporting the drill, follow and check these items:

### **Cylinder Locks**

**Refer to Figure 11**

Cylinder locks ① are located near both hydraulic cylinders. With drill fully raised place lock over rod of cylinder and secure in place with pin and clip.

#### **NOTE:**

The cylinder locks can be engaged or disengaged only after the drill is fully raised.

### **Unload Drill Box**

The drill can be transported with a full box of grain, but the added weight will increase stopping distance and decrease maneuverability. Unload drill box before transporting if at all possible.

### **Clearance**

Remember that the drill is wider than the tractor. Allow safe clearance.

### **Road Rules**

Comply with all federal, state and local safety laws when traveling on public roads.

### **Lock-out Hub**

**Refer to Figure 12**

Make sure drive lock-out hub on both sides of drill are disengaged before transporting. This will prevent excessive wear of drive system during transport.

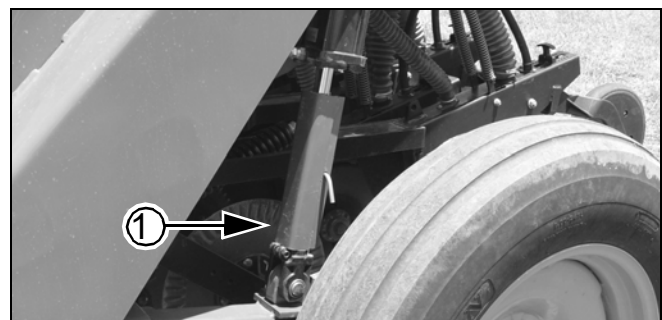

Figure 11  
Cylinder Locks

21706

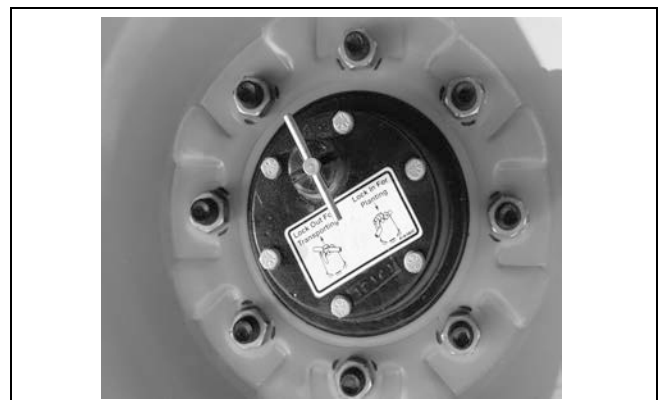

Figure 12  
Lock-out Hub

14741



## Parking and Unhitching

Perform the following steps when parking the drill. See “**Storage**” on page 31, to prepare for long-term storage.

1. Park drill on a level, solid surface.
2. Lower drill until openers are resting on the ground.
3. Securely block tires to prevent rolling.
4. Remove tongue jack (1) from storage mount. Pin the jack on the side of the tongue. Do not extend the jack at this time.

### Refer to Figure 13

5. If the drill has a jack with angle adjustment as shown in the illustration, do the following:

### **WARNING**

*Do not adjust the jack angle without being hitched and connected to a tractor.*

Before operating the jack, make sure the foot (2) of the jack is parallel to the ground.

If the foot is not parallel to the ground, loosen the three nuts (3) in the middle of the jack adjustment plate (4). Rotate the jack so the foot is parallel to the ground and tighten the three nuts.

If the foot is parallel to the ground, make sure the three nuts (3) in the middle of the jack adjustment plate (4) are tight.

6. If ground is soft, place a board or plate under the foot.
7. Extend jack until tongue weight is off tractor drawbar.
8. Unplug hydraulic hoses and wiring harness from tractor. Do not allow hose ends or harness ends to rest on the ground.
9. Remove hitch bolt and safety chain from tractor drawbar.

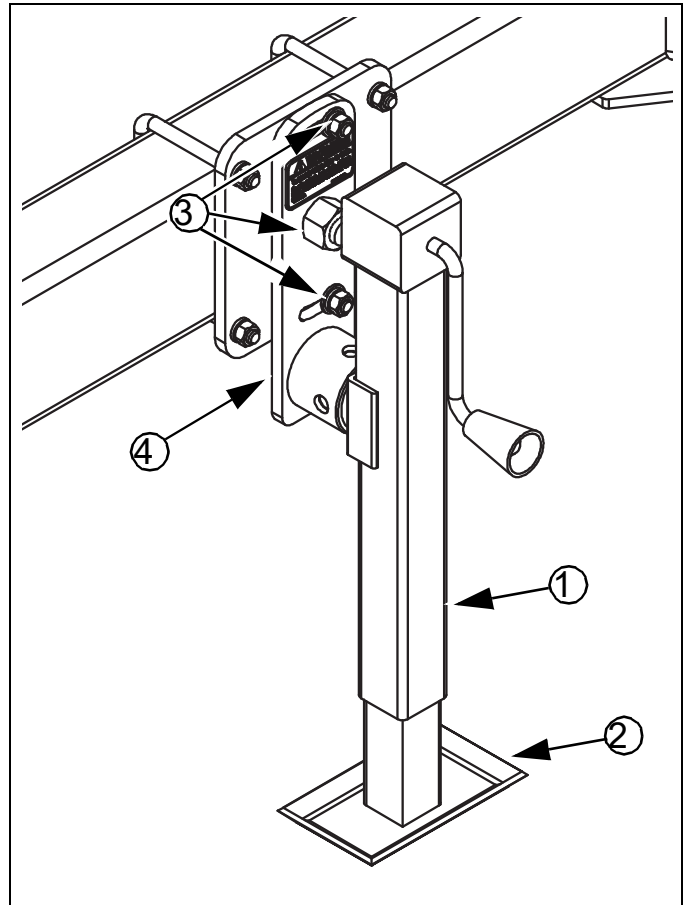

Figure 13  
Jack Angle Adjustment

68330



## Adjustments

### Coulter Adjustments

A no-till coulter ① is mounted directly ahead of each opener on the drill. The coulters cut through heavy trash and make a groove in the soil for the openers. The coulters are mounted on the drill frame so coulter cutting depth changes as the drill is raised and lowered.

To set drill seeding depth, you must:

1. Set coulter depth with hydraulic stop.
2. Set opener depth with T-handles on press wheels.
3. If soil conditions make it necessary, increase coulter down pressure by adding weights.

If necessary, adjust individual coulters or openers to seed in tire tracks, see “**Individual Coulter Adjustment**” on page 23.

Coulter cutting depth is controlled by a depth control valve.

The amount of coulter down force needed to cut a soil groove varies with soil conditions. Adding weight or shortening the coulter spring increases coulter down pressure and cutting force.

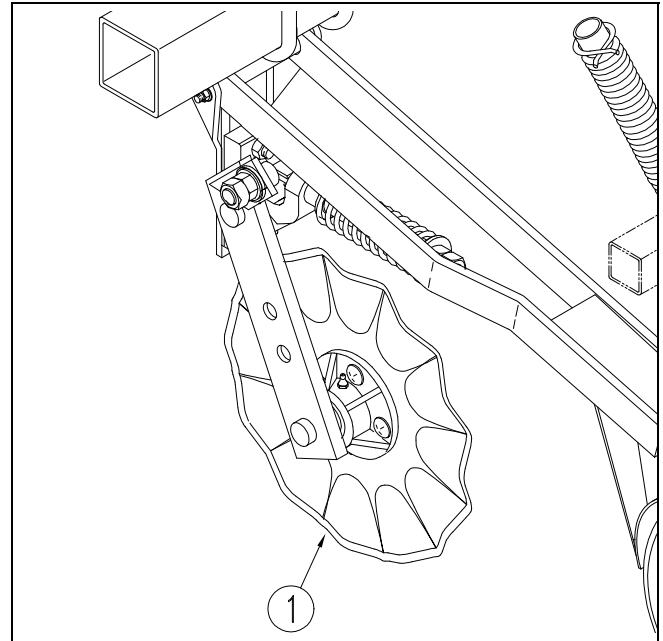

Figure 14  
Coulter

13985

### Coulter Depth Control

The master-slave lift cylinders on your drill control the depth of the coulters. A depth valve regulates the retracted length of these cylinders.

#### Refer to Figure 15

1. Slightly raise drill with depth stop engagement arm on the rock shaft not touching the valve.
2. Turn the depth control knob clockwise. Each rotation lowers the coulters approximately  $\frac{1}{4}$  inch.
3. Raise and lower drill a few times to recheck depth.

#### NOTE:

Changing depth of coulters will effect planting depth of openers. Press wheels will need to be adjusted accordingly.

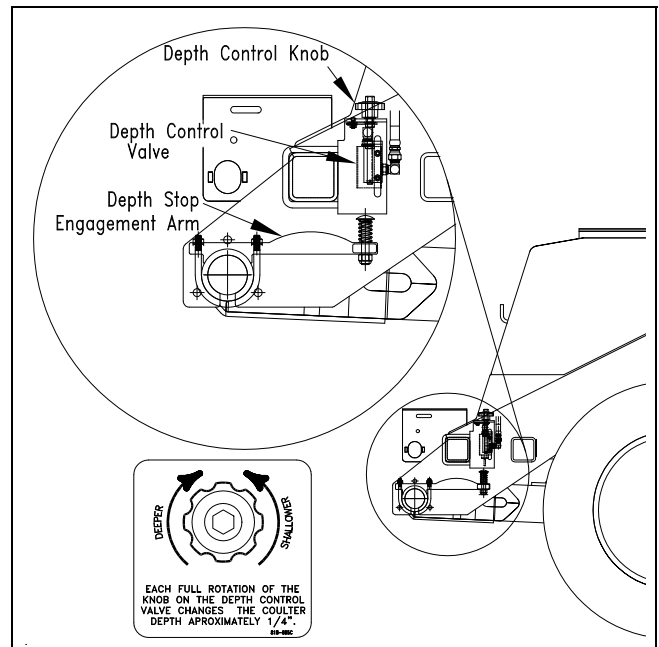

Figure 15  
Coulter Depth Stop

21708

## Coulter Down Pressure

### Weights

If more weight is required for your soil conditions, add weights to weight brackets located on box frame. No more than 1100 pounds for the 706 (550 pounds per side) and 1500 pounds for the 1006 (750 pounds per side) should ever be added. Add an equal amount of weight to each end of drill. Refer to Figure 16.

Pounds Per Coulter			
	7 inch	7-1/2 inch	8 inch
Empty Drill	274	282	290
Drill with 300 pounds added	304	314	323
Drill with 600 pounds added	334	345	356

Figure 16  
Weight Chart

### Spring Length

#### Refer to Figure 17

Coulter springs are preset at 9 7/8 to 10 inches, giving coulters an initial operating force of 400 pounds. This setting is adequate for many difficult no-till conditions.

### **CAUTION**

*Resetting coulters shorter than 9 3/4 inches may contribute to premature failure of parts and warranty will be voided. If additional force is needed, add weights to drill.*

For lighter no-till conditions where rocks or other obstructions are a problem, you can lengthen coulters to protect coulters from impact.

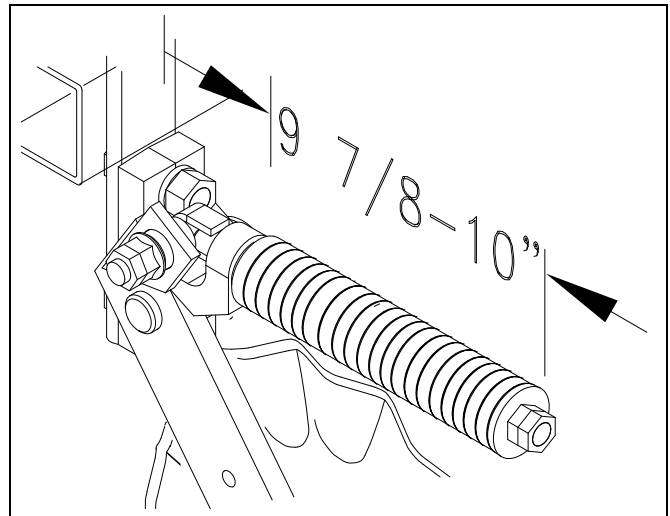

Figure 17  
Coulter Spring Length

20482

### Individual Coulter Adjustment

#### Refer to Figure 18

Individual coulters can be lowered if coulters follow in tractor tire tracks and do not give satisfactory depth. To do so:

1. Loosen  $\frac{5}{8}$  inch jam nuts on  $\frac{5}{8}$  inch square head set screws. Then loosen set screws.
2. Lower coulters to desired depth.
3. Tighten set screw on side of coulters clamp first. This squares coulters bar in clamp.
4. Tighten set screw on front of coulters clamp. Then tighten both  $\frac{5}{8}$  inch jam nuts on each set screw.

#### **NOTE:**

Torque  $\frac{5}{8}$  inch set screws 85-100 ft-lbs to obtain adequate holding force.

Spring Length	Initial Vertical Coulter Force
10-1/2 inches	175 pounds
10-1/4 inches	300 pounds
10 inches	400 pounds
9-5/8 inches	535 pounds

Figure 18  
Spring Length Chart

## Opener Adjustments

### Opener Down Pressure

#### Refer to Figure 19

Opener springs provide the down pressure necessary for opener disks to open a seed trench. The springs allow the openers to float down into depressions and up over obstructions.

Each opener spring can be adjusted for down pressure. This is useful when penetrating hard soil and for planting in tractor tire tracks.

To adjust the pressure, remove “W” clip at bottom of spring. Place “W” clip in a higher hole in spring rod for more pressure or in a lower hole for less pressure.

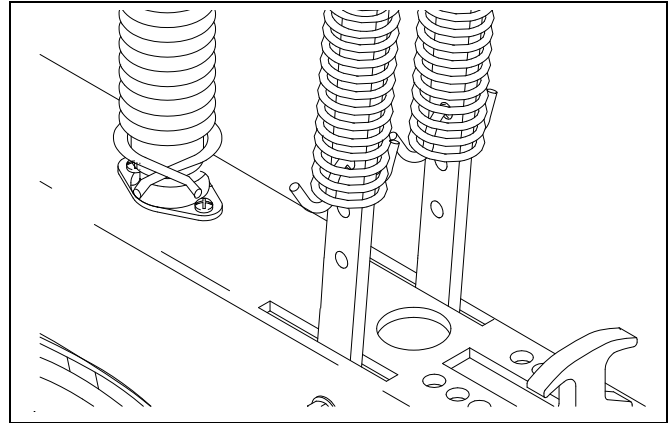

Figure 19  
Maximum Pressure on Opener

12103

### Opener Seeding Depth

#### Refer to Figure 20

A press wheel attached to each opener body controls seeding depth. To maintain consistent depth, the relationship between the bottom of the opener disks and press wheel is fixed upwardly by an adjustable stop on each opener.

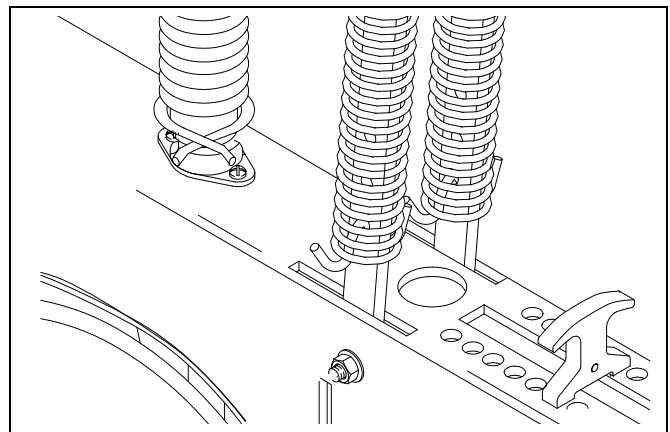

Figure 20  
Minimum Pressure on Opener

12102

#### Refer to Figure 21

The press wheels also close the seed trench and gently press soil over seed. To provide consistent soil firming, press wheels are free to move down from normal operating position. This maintains pressing action even if opener disks encounter obstructions or hard soil.

Set opener seeding depth by adjusting press-wheel height. To adjust, first raise drill slightly, then lift and slide T-handles ① on top of openers as shown in Figure 2.

- For shallower seeding, slide T-handles toward drill.
- For deeper seeding, slide T-handles away from drill.

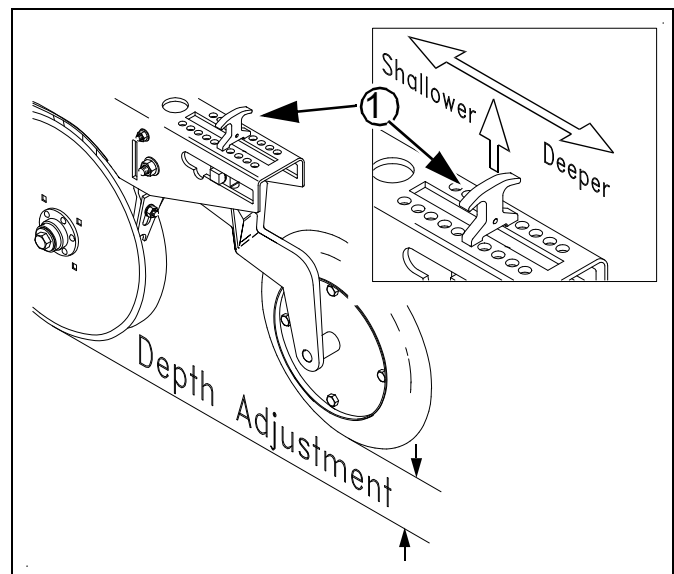

Figure 21  
Press Wheel Adjustment

15659

## Disk Scraper Adjustment

### Refer to Figure 22

To keep opener disks turning freely, dirt scrapers are mounted between disks to clean as the disks rotate. As field conditions vary, scrapers may need to be adjusted. In damp conditions, scrapers may need to be lowered. If openers are not turning freely, scrapers may need to be raised.

To adjust scrapers, loosen 3/8 inch bolt ① and move scraper as needed.

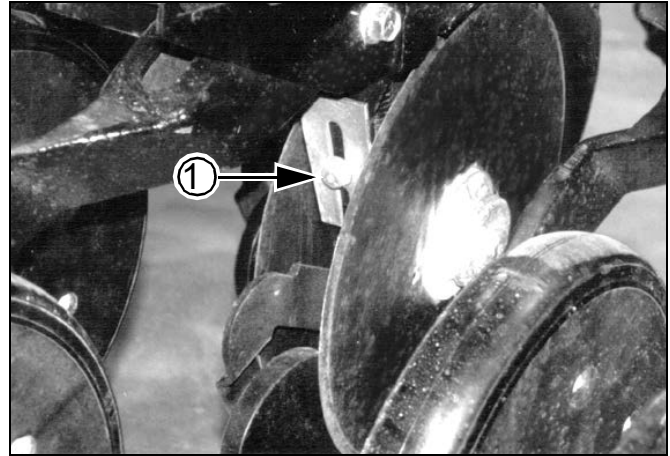

Figure 22  
Disk Scraper Adjustment

16153

## Disc Blade Adjustments

Opener disc angle and stagger is not adjustable, but disc-to-disc spacing is, and may need attention as discs experience normal wear. Spacers must be reset when blades are replaced.

### Refer to Figure 23

The ideal spacing causes the blades to be in contact for about one inch. If you insert two pieces of paper between the blades, the gap between them should be  $1/2$  to  $1\frac{3}{4}$  in. (1.3 to 4.4 cm).

If the contact region is significantly larger or smaller (or there is no contact at all), it needs to be adjusted by moving one or more spacer washers. If the contact region varies with blade rotation, one or both blades is likely bent and in need of replacement.

### Adjusting Disc Contact

## CAUTION

### Sharp Object Hazard:

Row unit disc blades may be sharp. Use caution when making adjustments in this area.

### Refer to Figure 24

1. Raise the drill and lock the lift-assist cylinders.
2. Remove the bolt ① retaining the opener disc on one side. Carefully remove the disc, noting how many spacers ② are outside the disc and inside the disc. Do not lose the hub components and dust cover ③.
3. To reduce the spacing between the discs (the normal case), move one spacer washer from the inside to the outside of the disc.
4. Re-assemble and check disc contact.

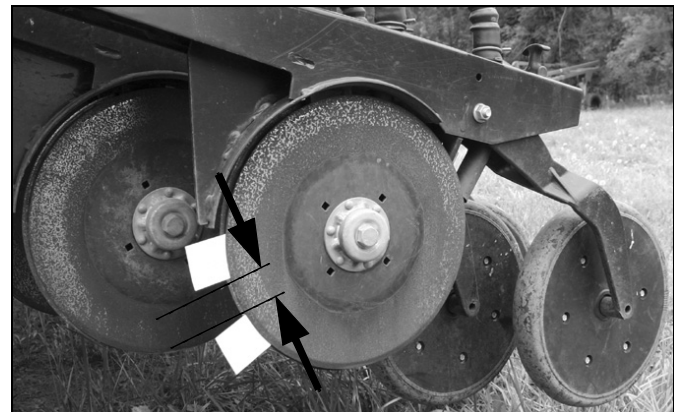

Figure 23  
Checking Disc Contact

26451

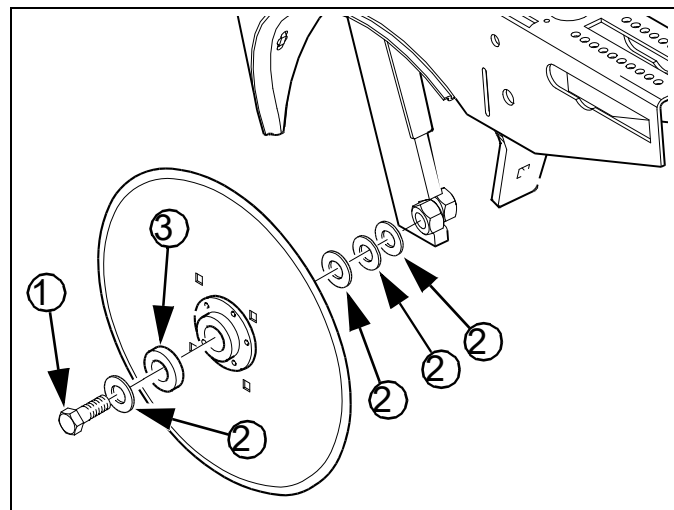

Figure 24  
Adjusting Disc Spacers

26385



## Gauge Wheel Idler Adjustment

### Refer to Figure 25

Located inside the left hand gauge wheel arm is two idler sprockets which should be readjusted after the first 100 acres of drill use. From then on, readjust at the beginning of each season.

To adjust, move front idler sprocket on top of chain down by loosening jam nut ① and screwing in adjustment stud ②.

Tighten jam nut to maintain idler position.

#### NOTE:

Do not over-tighten chains. To do so will cause excessive wear.

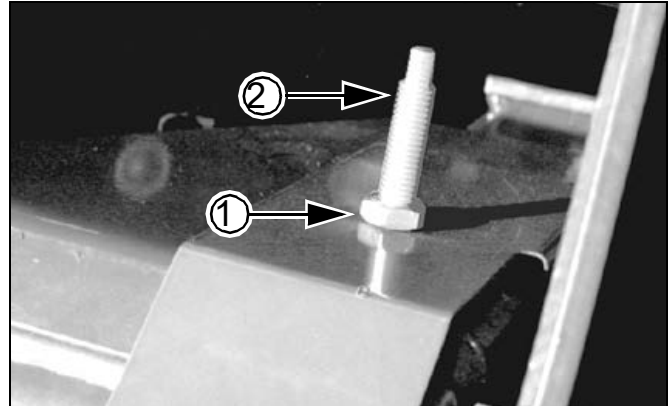

Figure 25  
Gauge Wheel Idler Adjustment

14744

## Drive Clutch

### Refer to Figure 26

The main drive clutch on your drill is a mechanical-release, jaw-style design. You may need to adjust the clutch for proper engagement and disengagement.

When properly adjusted, the cam plates ① will disengage the clutch jaws completely when the drill is raised. When lowered in field position, clutch jaws should be engaged.

To adjust, loosen bolts on clutch tab ②. Slide tab forward or back to change point at which cam plates meet. When satisfied with adjustment, tighten bolts on clutch tab.

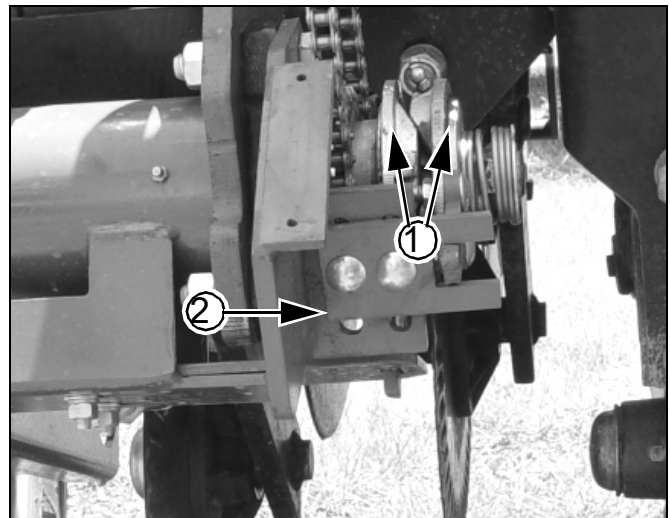

Figure 26  
Drive Clutch

21709

## Drive Train Operation

### Refer to Figure 27

Check all chain idlers at beginning of each season for proper adjustment. Check that each idler is taking up excess chain slack. The access door ① is located on the top side of the gauge wheel arm near the pivot end.

After first 100 hours of use and at beginning of each season, readjust idler sprocket in left wheel arm. To access idlers, remove access door.

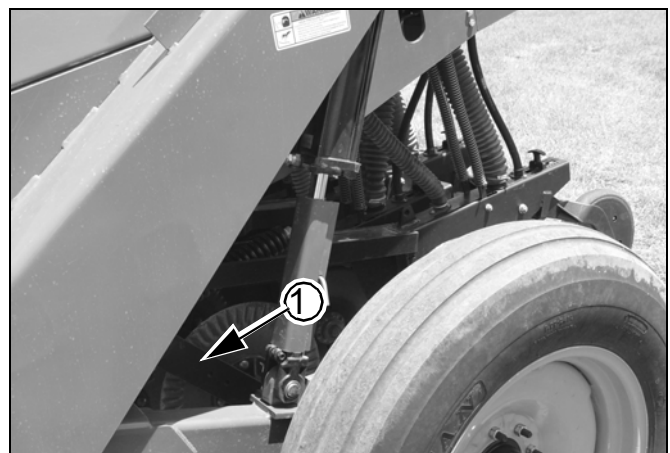

Figure 27  
Access Door

21781

**Refer to Figure 28**

To adjust idler sprocket, move top idler sprocket ② down into chain by loosening jam nut and screwing in adjustment stud ③. Tighten jam nut to maintain idler position.

**NOTE:**

Do not over tighten chains. Over tightening chains will cause excess wear on idlers and drive components. Be sure chain is installed with the chain connector link retainer towards the centerline and the clip opening (split end) faces the opposite way of the chain travel.

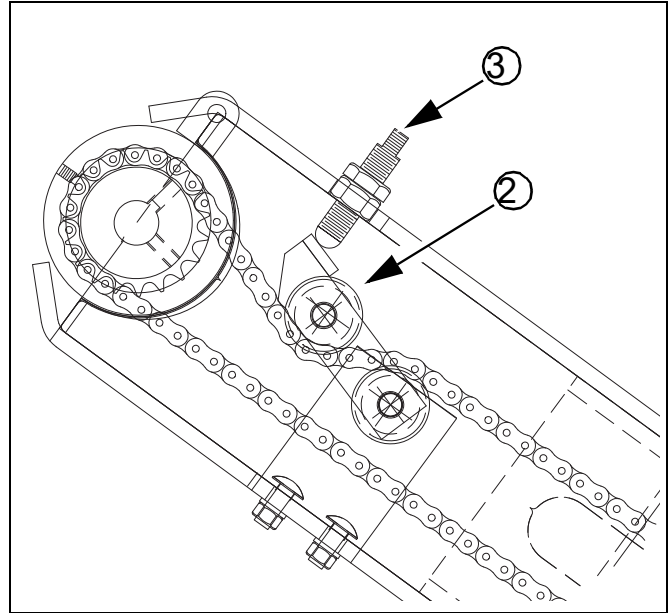

Figure 28  
Idler Sprocket Adjustments

**Spring Tine Harrow****Harrow Tine Angle****Refer to Figure 29**

The drawing on the right shows a successful harrow position for no-till and minimum-till conditions. Because of different soil moisture, trash levels and trash types, you may need to reposition the tube frame or tines. Initially position the frame and tines as shown, then readjust as necessary.

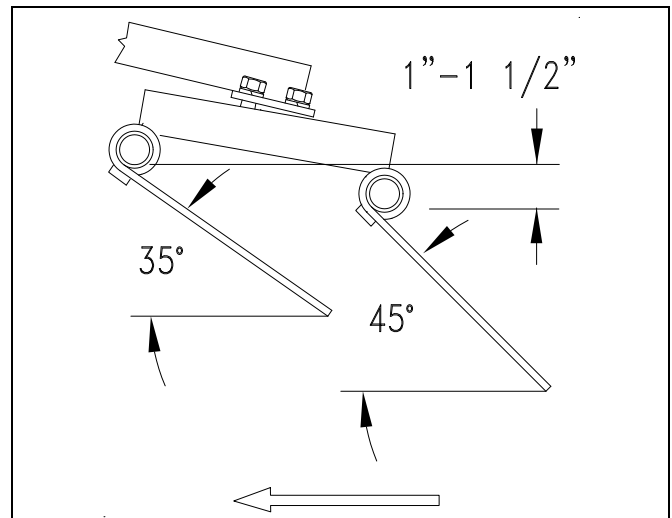

Figure 29  
Tine Angle

16297

## Harrow Frame and Tine Adjustment

### Refer to Figure 30

To adjust harrow frame loosen the four hex nuts ① on the U-bolts and rotate frame tube ② as necessary.

To adjust tines, loosen the four  $\frac{1}{2}$ -inch hex nuts ③ on the  $\frac{1}{2}$ -inch U-bolts ④ on the support bar ⑤. Rotate tine tubes ⑥ so tines ⑦ are against stop bushings ⑧ and are angled back as necessary. Tighten hex nuts on U-bolts.

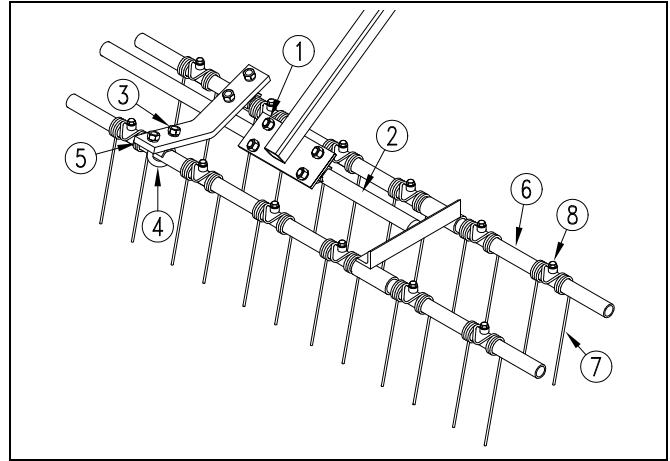

Figure 30  
Frame and Tine Adjustment

16297

## Harrow Chain

### Refer to Figure 31

In clean, tilled, extremely loose soils, harrow chain may need to be shortened to lift harrow off the ground.

To adjust chain, support the harrow to remove weight from the harrow arms ①. Remove the lower bolt ② and select a different chain link.

**NOTE:**  
Keep the harrow arms at the same length.

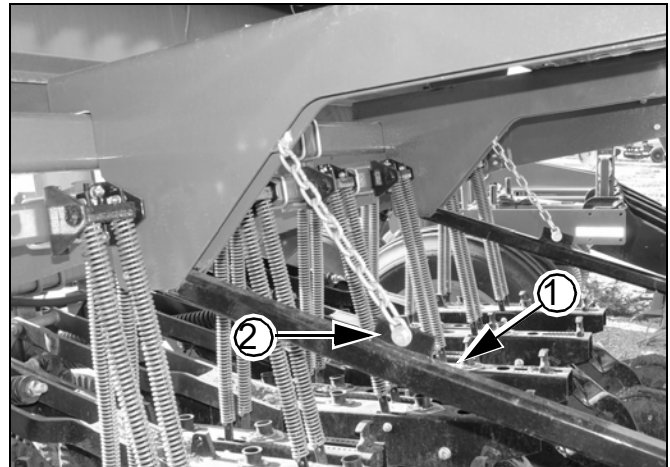



Figure 31  
Harrow Chain Adjustment

21712





## Troubleshooting

Problem	Cause	Solution
<b>Uneven seed spacing or uneven stand</b>	Excessive field speed.	Reduce field speed.
	Feed cups plugging.	Clean out feed cups.
	Seed tubes plugging.	Clean out seed tubes.
	Opener disks not turning freely.	See “Opener disks not turning freely” in this Troubleshooting section.
	Opener not penetrating low spots.	Adjust opener, page 24.
		Use faster drive type speed and close feed cup flutes to a more narrow position.
<b>Uneven seed depth</b>	Excessive field speed.	Reduce field speed.
	Planting conditions too wet.	Wait until drier weather.
	Drill not level.	Readjust, page 17.
	Incorrect hitch height.	Readjust hitch height, page 14.
<b>Opener disks not turning freely</b>	Trash or mud build up on disk scraper.	Adjust scraper, page 25.
	Scraper adjusted too tight, restricting movement.	Adjust scraper, page 25.
	Failed disk bearings.	Replace disk bearings.
	Bent or twisted opener frame.	Replace opener frame.
	Planting conditions too wet.	Wait until drier weather.
	Too much opener down pressure.	Readjust opener down pressure, page 24.
	Incorrect press wheel adjustment.	Readjust press wheel, page 24.
<b>Actual seeding rate different than desired</b>	Improper tire size or air pressure.	Check tire size and air pressure, page 39.
	Build up of seed treatment in feed cup.	Clean seed treatment from feed cups.
	Incorrect rate adjustment.	Check gearbox setting and seed-rate handle setting, see the seed rate book.
<b>Excessive seed cracking</b>	Excessive field speed.	Reduce field speed.
	Feed cup flutes not open enough.	Open feed cups to a wider position.
	Feed cup door handle not open enough.	Open feed cup door handle to a lower position.
<b>Acrometer does not measure accurately.</b>	Incorrect tire size or air pressure.	Correct tire size or air pressure, page 39.
	Excessive overlap or gaps between passes.	Avoid overlap or gaps.
	Soil conditions.	Loose soil and slippage will cause variations in acres registered.
	Acrometer not for your width of drill.	See the parts manual.
	Actual field size different.	Verify field size.

Problem	Cause	Solution
<b>Press wheels not compacting soil as desired</b>	Too wet or cloddy.	Wait until drier weather or rework ground.
	Incorrect hitch height.	Readjust hitch height, page 14.
	Press wheel depth does not match coulter depth.	Readjust press wheel depth, page 24.
	Not enough down pressure on disk openers.	Increase down pressure on openers, page 24.
<b>Grain box not emptying evenly</b>	Some models do not have same number of feed cups between each divider of bulkhead.	
<b>Press wheel or openers plugging</b>	Planting conditions too wet.	Wait until drier weather.
	Too much down pressure on openers.	Reduce down pressure on openers, page 24.
	Backed up with drill in the ground.	Clean out and check for damage.
	Failed disk bearings.	Replace disk bearings.
	Scraper worn or damaged.	Replace scraper.
<b>Raising and lowered drill is rough or uneven</b>	Wheel arm pivot casting needs lubricating.	Lubricate wheel arm pivot castings.
	Leaking hydraulic fittings.	Check fittings for leaks, see page 17 for safety message.
	Rephasing cylinders not bled properly.	See page 17 for information.
<b>Feed cup sprockets locked up or twisted feed cup drive shaft</b>	Foreign matter lodged in one or more feed cup sprockets.	Clean out feed cup sprockets. Use clean seed.
	Dried liquid insecticide inside feed cups.	Remove build up by disassembling each feed cup and scraping foreign substance from turn surfaces.
<b>Coulters not going deep enough</b>	Not enough weight.	See page 23 for correct weight.
<b>Coulters and drill going too deep</b>	Too much weight.	See page 23 for correct weight.
	Incorrect depth control setting.	Reset depth control, page 22.
	Incorrect press wheel adjustment.	Set press wheels to a shallower depth.
<b>Coulters and openers plugging in no-till conditions</b>		Drill at a slight angle to rows.
<b>Small seeds box not emptying evenly</b>	Adjustable divider not set evenly.	Move adjustable divider to create more volume in areas that run out first.
<b>Chain</b>	Debris, retainer clip	Be sure retainer clip is facing opposite way of chain travel.



## Maintenance and Lubrication

### Maintenance

Proper servicing and maintenance is the key to long implement life. With careful and systematic inspection, you can avoid costly maintenance, downtime and repair.

Always turn off and remove the tractor key before making any adjustments or performing any maintenance.

#### **WARNING**

*You may be severely injured or killed by being crushed under the falling implement. Always have transport locks in place and frame sufficiently blocked up when working on implement.*

#### **WARNING**

*Escaping fluid under pressure can have sufficient pressure to penetrate the skin. Check all hydraulic lines and fittings before applying pressure. Fluid escaping from a very small hole can be almost invisible. Use paper or cardboard, not body parts, and wear heavy gloves to check for suspected leaks. If injured, seek medical assistance from a doctor that is familiar with this type of injury. Foreign fluids in the tissue must be surgically removed within a few hours or gangrene will result.*





1. After using the drill for several hours, check all bolts to be sure they are tight.
2. Lubricate areas listed under “Lubrication”, page 32.
3. Adjust idlers to remove excess slack from chains. Clean and use chain lube on all roller chains as needed.
4. Inflate tires as specified on “**Tire Information**” on page 39.
5. Clean out build up of seed treatment in feed cups.
6. Replace any worn, damaged or illegible safety decals. Order new decals from your Great Plains dealer. See “**Safety Decals**” on page 5.

### Storage



Store drill where children do not play. If possible, store the drill inside for longer life.

1. Unload seed box.
2. Thoroughly clean seed and seed-treatment residue from boxes and feed cups.
3. Remove any dirt and debris that can hold moisture and cause corrosion.
4. Lubricate and adjust all roller chains.
5. Take special care to oil feed cup drive sprocket in its square bore.
6. Lubricate areas noted under “Lubrication”, page 32.
7. Inspect drill for worn or damaged parts. Make repairs and service during the off season.
8. Use spray paint to cover scratches, chips and worn areas on the drill to protect the metal.
9. Disconnect seed hoses from openers. Permanent elongation and premature cracking of hoses may occur if stored connected.
10. Cover with a tarp if stored outside.

## Lubrication and Scheduled Maintenance

 Multi-purpose spray lubricant	 Multi-purpose grease lubricant	 Multi-purpose oil lubricant	 Inspection	 50 Intervals (operating hours) at which service is required
---	--	---	---	--

### Clutches

	 8 Hrs.
---	--

Two zerks on each.



Smear grease on clutch engagement teeth.

Type of Lubrication: Grease

Quantity = Until grease emerges



### Grease Banks



	 8 Hrs.
---	--

Type of Lubrication: Grease

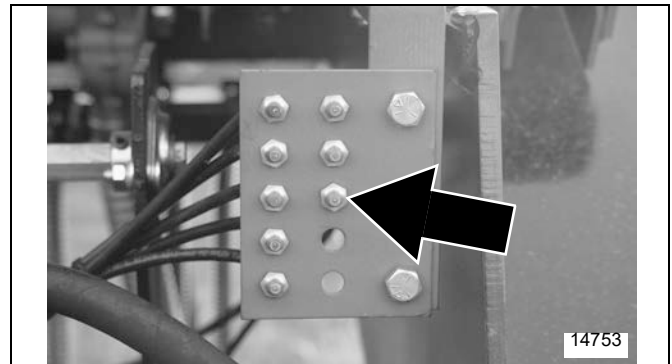
Quantity = Until grease emerges



### Drive Chains

	 As Required
---	---

See “**Drive Train Operation**” starting on page 26 for more information.

Type of Lubrication: Chain Lube

Quantity = Coat thoroughly.

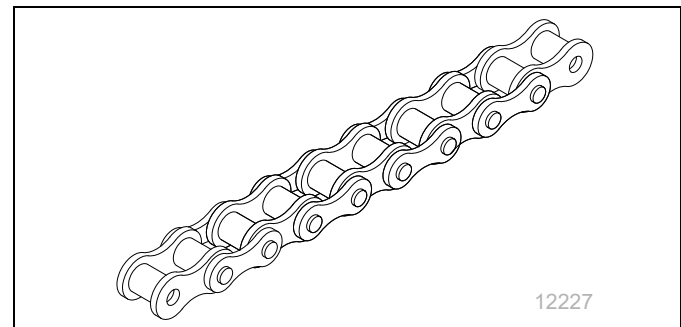

**Fertilizer Tray Bearings**

Both ends of shaft

Type of Lubrication: Grease

Quantity = Until grease emerges

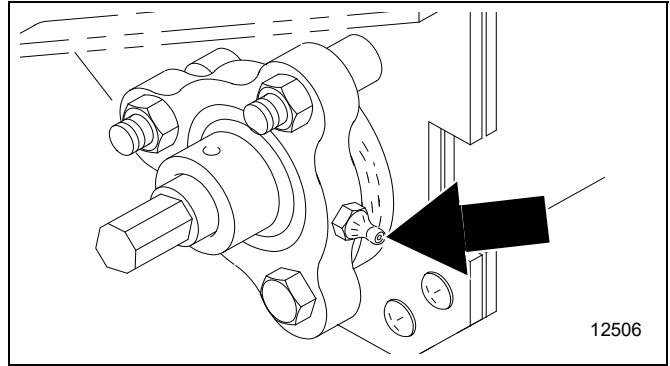
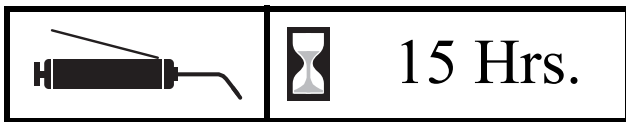
**Gauge Wheel Arms**

Type of Lubrication: Grease

Quantity = Until grease emerges

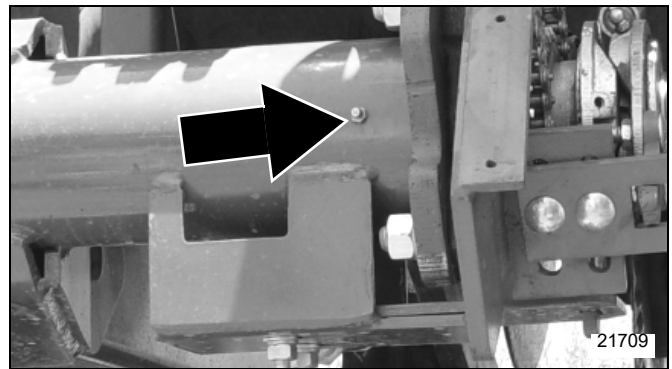
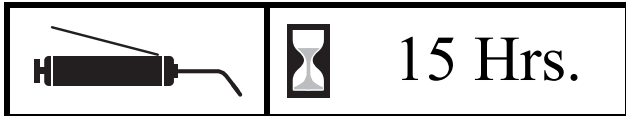
**Small Seeds Shaft Bearings (Option)**

1 zerk total

Type of Lubrication: Grease

Quantity: Until grease emerges

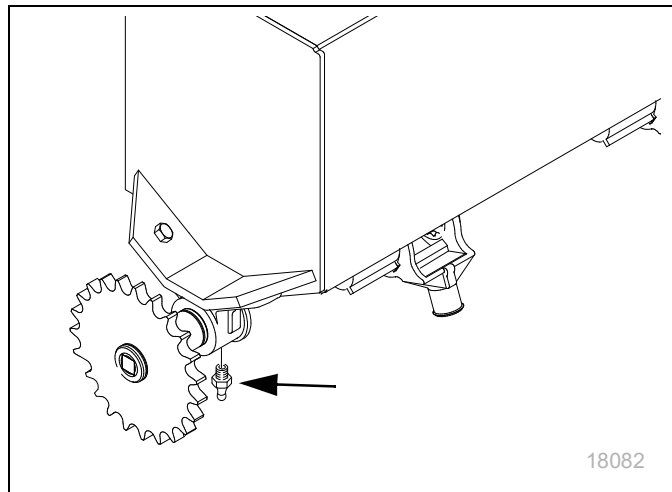

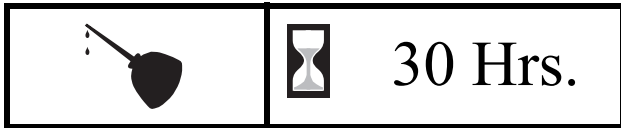
**Felt Barrier Seals**

1 seal at each shaft end, 2 total

Type of Lubrication: Oil

Quantity: Soak seal

If Small Seeds is also installed, access these seals from below or through the end wall gaps.

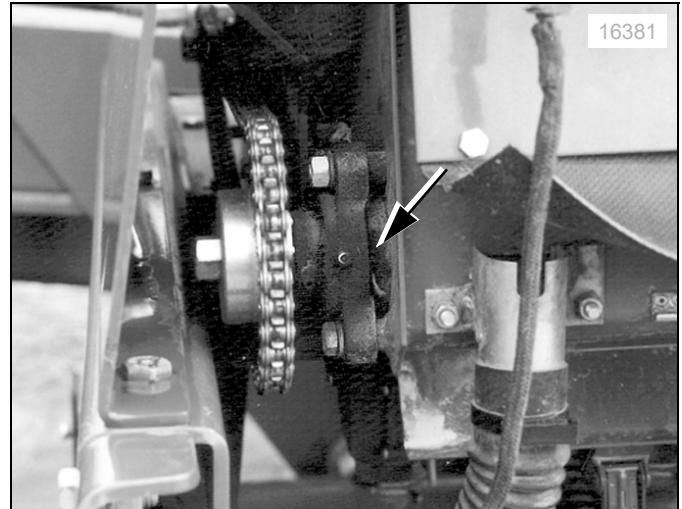
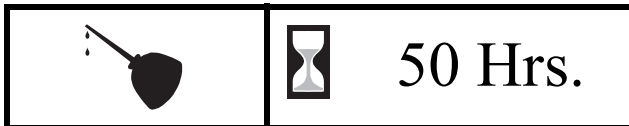
**Feed Cup Drive Shaft Sprocket**

1 sliding sprocket

Type of Lubrication: Oil

Quantity: Coat thoroughly

Move the Seed Rate adjustment handle back and forth to get oil into the square bore. Perform this with seed box empty, or handle may be difficult to set to 100.

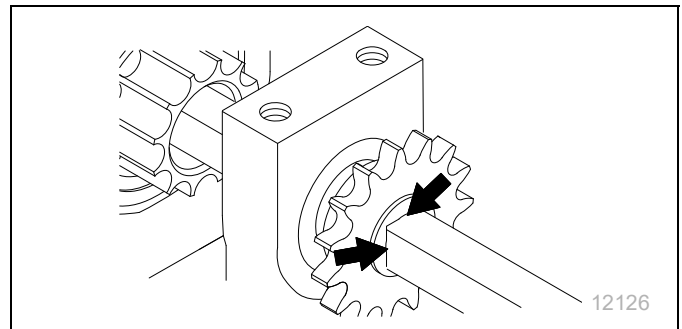
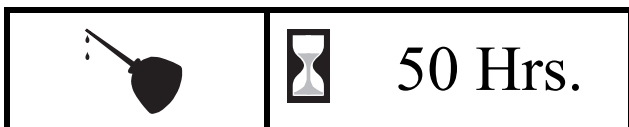
**Small Seeds Feed Cup Drive Sprocket**

Type of Lubrication: Oil

Quantity = Coat sprocket bore thoroughly

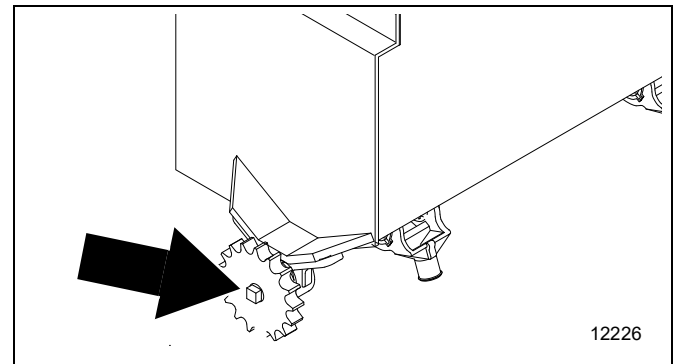

## Coulter Hub Bearings

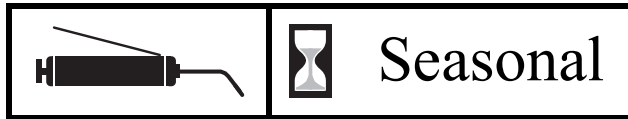

One zerk per coultter; 15 total

Type of Lubrication: Grease

Quantity = Until resistance is felt

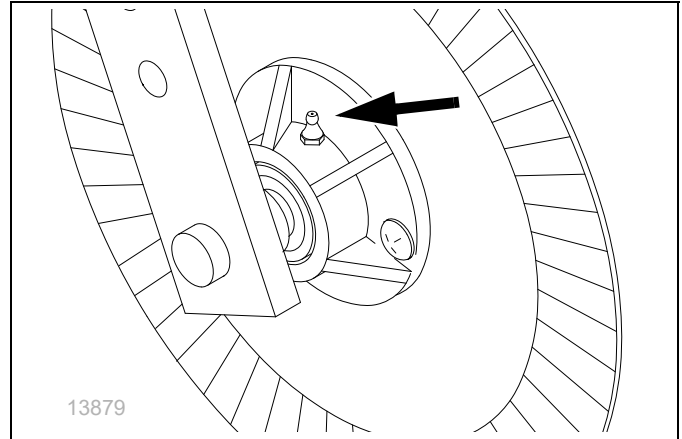

## Ground Drive Wheel Bearings



2 races per wheel; 4 total

Type of Lubrication: Grease

Quantity = repack

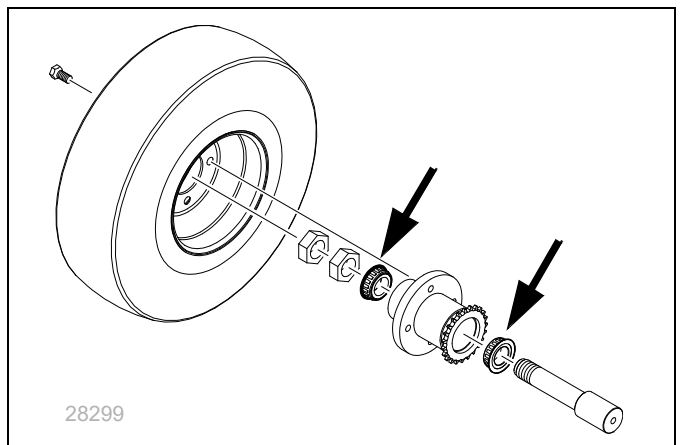

## Gearbox

The gearbox is lubricated and sealed at the factory. Under normal conditions, it does not require maintenance or lubrication.

If the gearbox has been opened for repair, repack all gears and around shaft bearings using at least 7 oz. of gear lube, part number 788067.

Keep moisture and dirt out of gearbox. Inspect (replace if needed) the rubber seals on gearbox drive and shifter shafts.

Spread a small skim coat of anaerobic sealant (Loctite® 525 or equivalent) to gear case mating surfaces before bolting them back together.

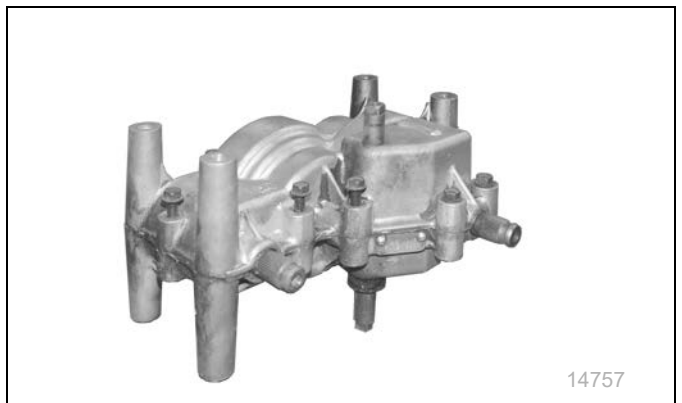

## NOTICE

*Use sparingly. Excess sealant may squeeze off the intended surface and lock bearings or gears.*



### Seed Box Agitator

The seed box agitator is designed to stir the seed directly above the metering cups. It is intended to cut down on the “bridging” of light fluffy seeds, and help to separate individual soybeans that become sticky from inoculant.

**NOTE:**

The seed box agitator will not guarantee consistent seeding of hard to meter seeds such as Brome Grass or “bin run” seed that contains crop residue.

For lubrication points, see “**Lubrication and Scheduled Maintenance**” on page 32.

To order the seed box agitator, contact your Great Plains dealer.

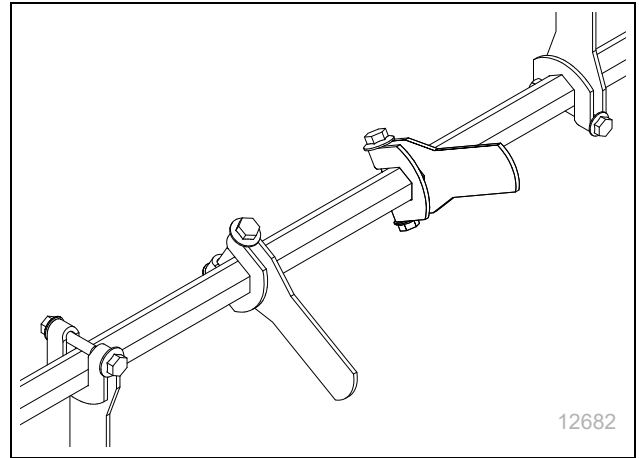

12682

	Agitator Packages row spacing (inches)			706	1006
	7	7.5	8	Part No	Part No
Without small seeds, native grass or fertilizer	●			118-893A	118-897
		●		118-895A	118-899A
			●	118-895A	118-901A
With small seeds, native grass or fertilizer	●			118-894A	118-898A
		●		118-896A	118-900A
			●	118-896A	118-902A

### Harrow Attachment

The coil-tine harrow finishes no-till surfaces by leveling and distributing residue for enhanced seed germination.

For information on how to adjust the harrow, see “**Spring Tine Harrow**” on page 27.

To order the harrow attachment, contact your Great Plains dealer.

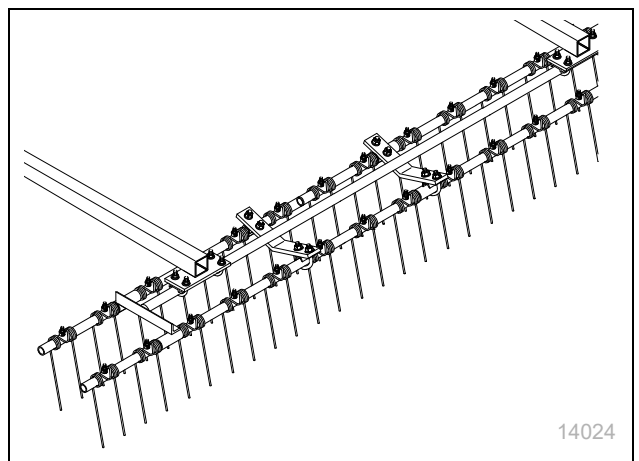

14024

Harrow Packages	Part Number
706 Harrow Attachment	116-278A
1006 Harrow Attachment	116-279A



## Fertilizer Attachment

The fertilizer attachment allows you to plant seed and apply fertilizer in the same field pass. The fertilizer box mounts on the rear of the main drill box. A fertilizer drive meters dry, granular fertilizer.

For fertilizer meter rate calibrating and charts, see “Fertilizer Meter Rate” in the seed rate book. For lubrication points, see “**Lubrication and Scheduled Maintenance**” on page 32.

To order the fertilizer attachment, contact your Great Plains dealer.

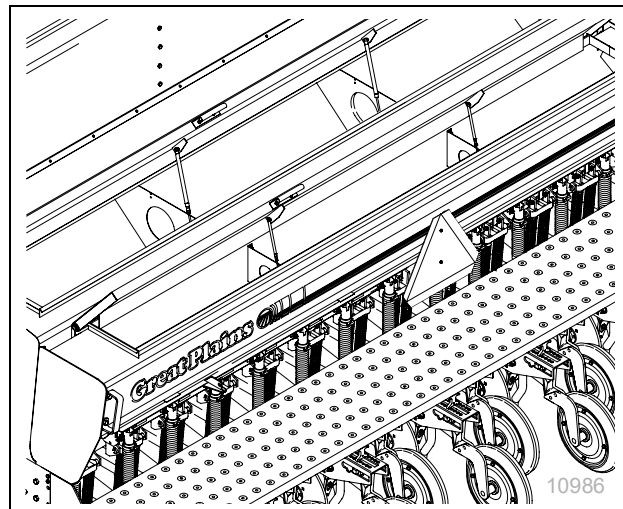

## Small Seeds Attachment

The small seeds attachment is designed to meter various small seeds. It is driven independently of the main seed box. The small seeds box is 0.24 bushel per foot (27.7 liters/meter) with a total capacity of 2.62 bushels (92.3 liters).

The small seeds attachment is available with two seed release point options: In row delivery and side delivery.

With the In row delivery, small seeds are metered and dropped between the disc blades or just in front of the press wheel.

With the side delivery, small seeds are metered and dropped just to the side of the opener furrow.

For seed rates and adjustments, see “Small Seeds Attachment” in the seed rate book. For lubrication points, see “**Lubrication and Scheduled Maintenance**” on page 32.

To order the small seeds attachment, contact your Great Plains dealer.

## Seed-Lok® Firming Wheels

The spring-loaded Seed-Lok® firming wheel presses seed directly into the bottom of the seed bed. The Seed-Lok® option provides more even emergence since seeds are planted and firmed at the same depth. Seed-Lok® can be used on all units except native grass, unless native grass tube is removed during Seed-Lok® use.

To order the Seed-Lok® firming wheels, contact your Great Plains dealer.

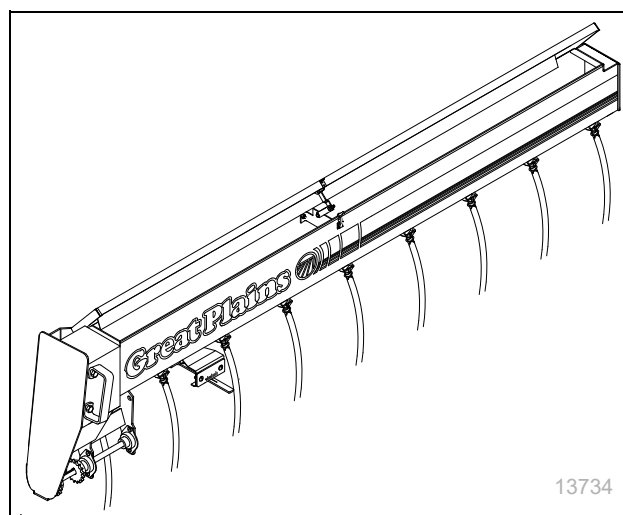

Seed-Lok® Packages	Part Number
Seed-Lok® Assembly	122-193K

## Series II Native Grass Attachment

The native grass attachment is designed to seed fluffy, hard-to-plant grasses.

For seed rates and adjustments, refer to “Native Grass Attachment” in the seed rate book.

To order the native grass attachment, contact your Great Plains dealer.



## Folding Tongue

The folding tongue is designed to allow narrower widths for trailer towing of drill and for space saving during storage.

To order the folding tongue, contact your Great Plains dealer.

Folding Tongue Packages	Part Number
1006 Folding Tongue	151-111A
706 Folding Tongue	151-114A

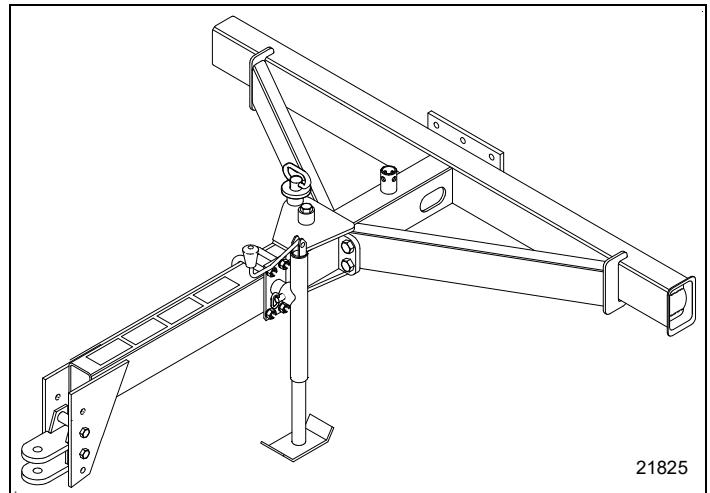



## Torque Values Chart

Bolt Size	Bolt Head Identification						Bolt Size	Bolt Head Identification					
	Grade 2		Grade 5		Grade 8			Class 5.8		Class 8.8		Class 10.9	
in-tpi <sup>a</sup>	N-m <sup>b</sup>	ft-lb <sup>d</sup>	N-m	ft-lb	N-m	ft-lb	mm x pitch <sup>c</sup>	N-m	ft-lb	N-m	ft-lb	N-m	ft-lb
1/4-20	7.4	5.6	11	8	16	12	M 5 X 0.8	4	3	6	5	9	7
1/4-28	8.5	6	13	10	18	14	M 6 X 1	7	5	11	8	15	11
5/16-18	15	11	24	17	33	25	M 8 X 1.25	17	12	26	19	36	27
5/16-24	17	13	26	19	37	27	M 8 X 1	18	13	28	21	39	29
3/8-16	27	20	42	31	59	44	M10 X 1.5	33	24	52	39	72	53
3/8-24	31	22	47	35	67	49	M10 X 0.75	39	29	61	45	85	62
7/16-14	43	32	67	49	95	70	M12 X 1.75	58	42	91	67	125	93
7/16-20	49	36	75	55	105	78	M12 X 1.5	60	44	95	70	130	97
1/2-13	66	49	105	76	145	105	M12 X 1	90	66	105	77	145	105
1/2-20	75	55	115	85	165	120	M14 X 2	92	68	145	105	200	150
9/16-12	95	70	150	110	210	155	M14 X 1.5	99	73	155	115	215	160
9/16-18	105	79	165	120	235	170	M16 X 2	145	105	225	165	315	230
5/8-11	130	97	205	150	285	210	M16 X 1.5	155	115	240	180	335	245
5/8-18	150	110	230	170	325	240	M18 X 2.5	195	145	310	230	405	300
3/4-10	235	170	360	265	510	375	M18 X 1.5	220	165	350	260	485	355
3/4-16	260	190	405	295	570	420	M20 X 2.5	280	205	440	325	610	450
7/8-9	225	165	585	430	820	605	M20 X 1.5	310	230	650	480	900	665
7/8-14	250	185	640	475	905	670	M24 X 3	480	355	760	560	1050	780
1-8	340	250	875	645	1230	910	M24 X 2	525	390	830	610	1150	845
1-12	370	275	955	705	1350	995	M30 X 3.5	960	705	1510	1120	2100	1550
1 1/8-7	480	355	1080	795	1750	1290	M30 X 2	1060	785	1680	1240	2320	1710
1 1/8-12	540	395	1210	890	1960	1440	M36 X 3.5	1730	1270	2650	1950	3660	2700
1 1/4-7	680	500	1520	1120	2460	1820	M36 X 2	1880	1380	2960	2190	4100	3220
1 1/4-12	750	555	1680	1240	2730	2010							
1 3/8-6	890	655	1990	1470	3230	2380							
1 3/8-12	1010	745	2270	1670	3680	2710							
1 1/2-6	1180	870	2640	1950	4290	3160							
1 1/2-12	1330	980	2970	2190	4820	3560							

- a. in-tpi = nominal thread diameter in inches-threads per inch
- b. N·m = newton-meters
- c. mm x pitch = nominal thread diameter in mm x thread pitch
- d. ft-lb = foot pounds

Torque tolerance + 0%, -15% of torquing values. Unless otherwise specified use torque values listed above.

25199

## Tire Information

Tire Inflation Chart		
Tire Size	Inflation	Torque
9.0 x 24" 8-Ply Rib Implement	40 psi (276 kPa)	170 lb ft (230 Nm)

Tire Warranty Information
<p>All tires are warranted by the original manufacturer of the tire. Tire warranty information is found in the brochures included with your Operator's and Parts Manuals or online at the manufacturer's web sites listed below. For assistance or information, contact your nearest Authorized Farm Tire Retailer.</p> <p>Manufacturer Web site                      Firestone <a href="http://www.firestoneag.com">www.firestoneag.com</a>                      Gleason <a href="http://www.gleasonwheel.com">www.gleasonwheel.com</a>                      Titan <a href="http://www.titan-intl.com">www.titan-intl.com</a>                      Galaxy <a href="http://www.atgtire.com">www.atgtire.com</a>                      BKT <a href="http://www.bkt-tire.com">www.bkt-tire.com</a></p>

## Specifications and Capacities

	706			1006		
Row Spacing, Inches	7	7.5	8	7	7.5	8
Rows Per Drill	11	10	10	16	15	14
Approx. Weight, Pounds	3,900 lb (1769 kg)	3,800 lb (1724 kg)	3,800 lb (1724 kg)	4,500 lb (2041 kg)	4,300 lb (1950 lb)	4,200 lb (1905 kg)
Working Width	7 feet (2.1 m)			10 feet (3.0 m)		
Transport Width	9 feet 10 inches (3 m)			12 feet 7 inches (3.8 m)		
Transport Height	6 feet 7 inches (2.0 m)			6 feet 7 inches (2.0)		
Transport Length	13 feet 10 inches (4.2 m)			13 feet 10 inches (4.2 m)		
Tongue Weight, Transport	700 lb (318 kg)			750 lb (340 kg)		
Tongue Weight, Field	460 lb (209 kg)			268 lb (123 kg)		
Approx. Seedbox Capacity	17.1 bushels (602.5 l)			23.75 bushels (836.9 l)		
Small Seeds	1.68 bushels (59.2 l)			2.4 bushels (84.6 l)		
Native Grass	7 bushels (246.7 l)			10 bushels (352.4 l)		
Fertilizer	6.5 cubic feet (184.1 l)			9.2 cubic feet (260.5)		
Dual Seed	7 bushels (246.7 l)			10 bushels (352.4 l)		
End Wheel Tires	9.00 x 24			9.00 x 24		
Tractor Requirements	55 horsepower (41 kw); one remote valve			75 horsepower (56 kw); one remote valve		

## Hydraulic Schematic

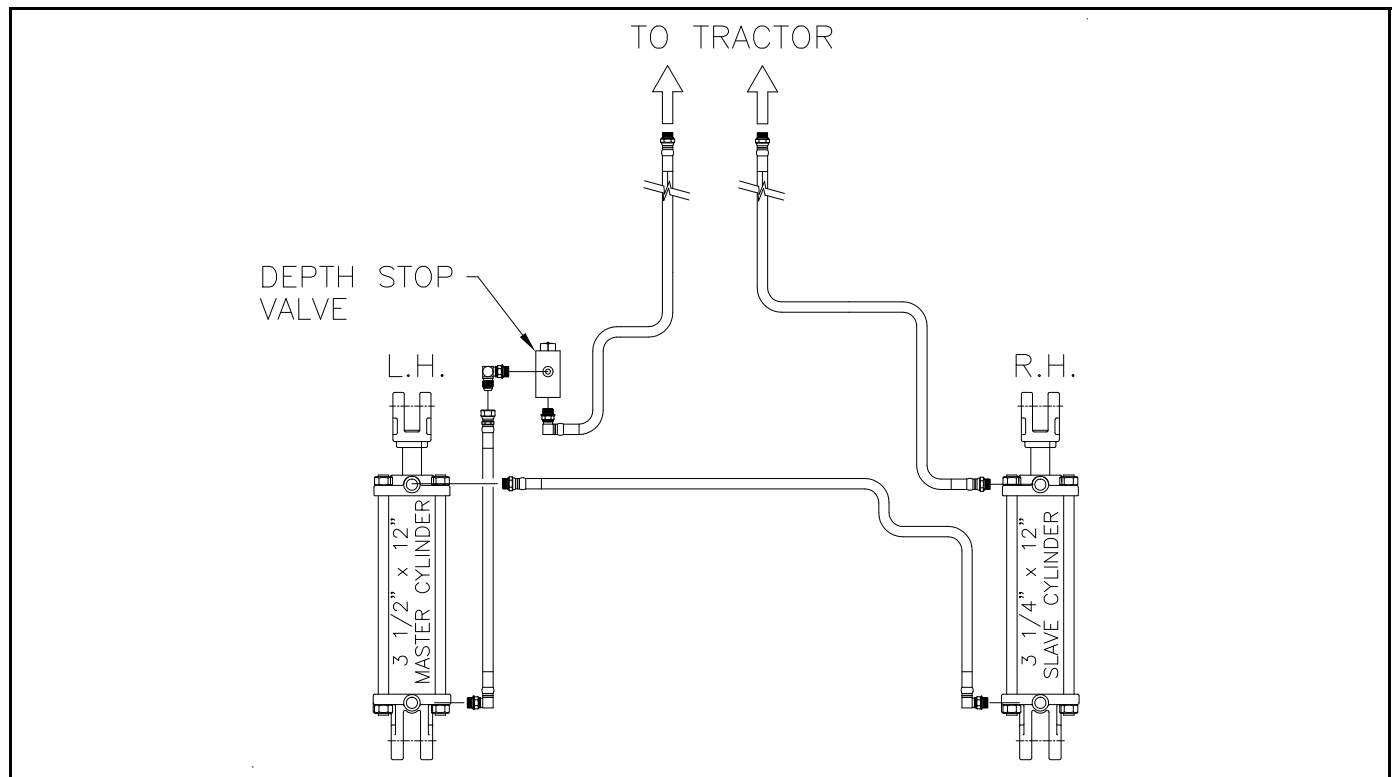

# Sprocket Configurations

## Seed Box

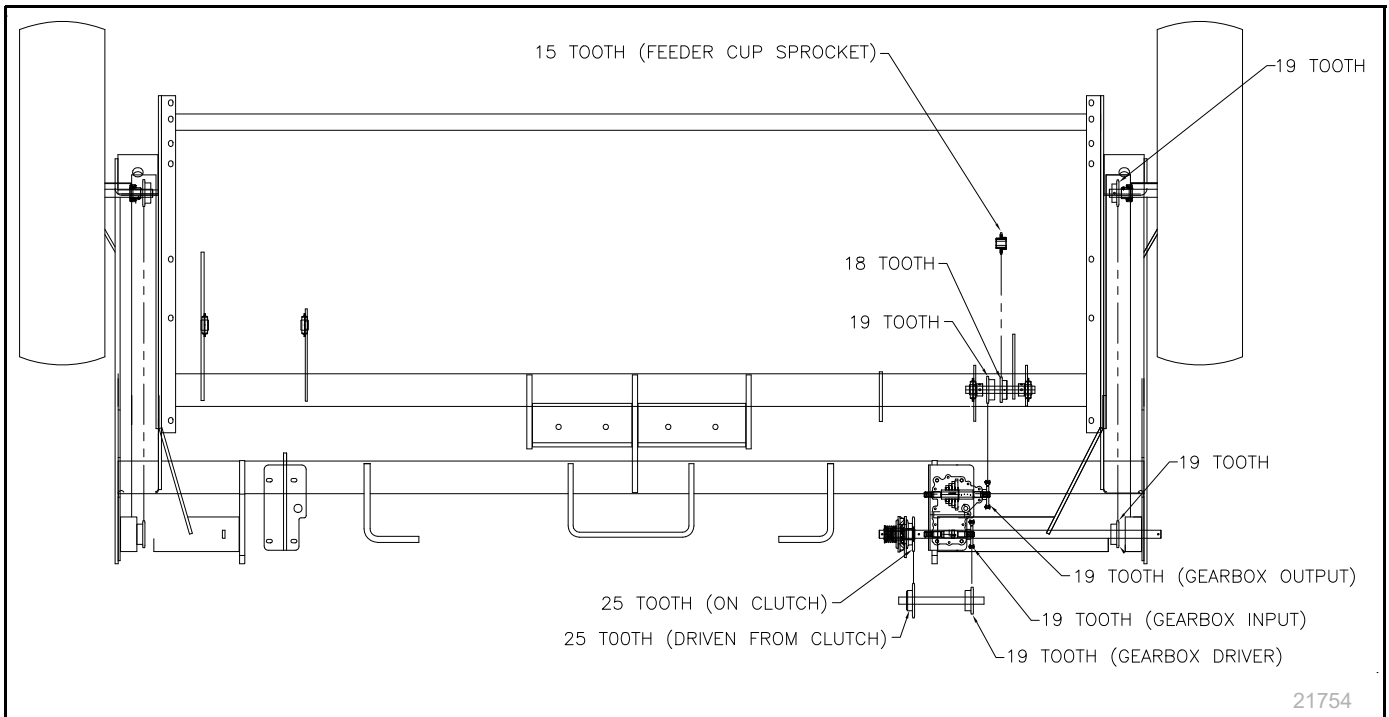

## Seed Box Agitator

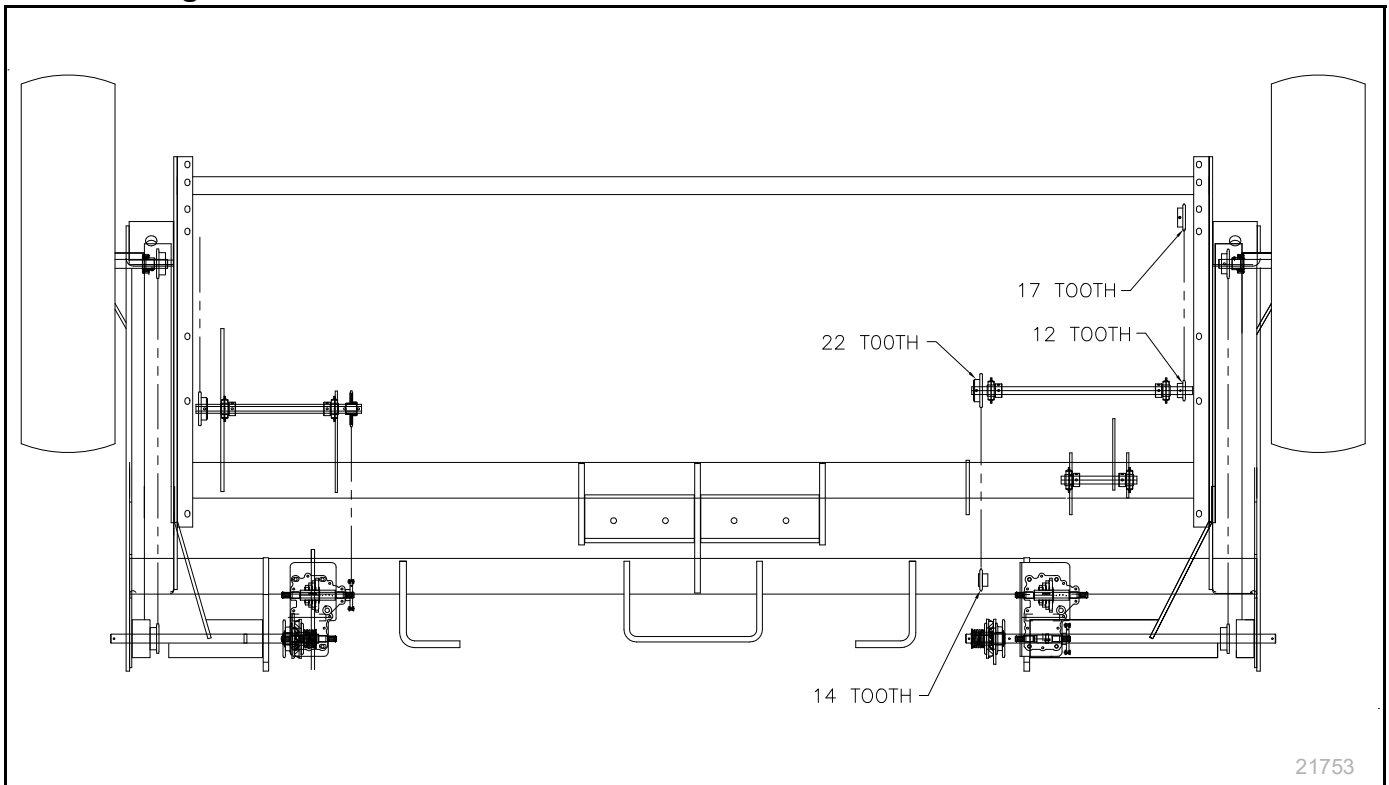

### Dual Seed Box

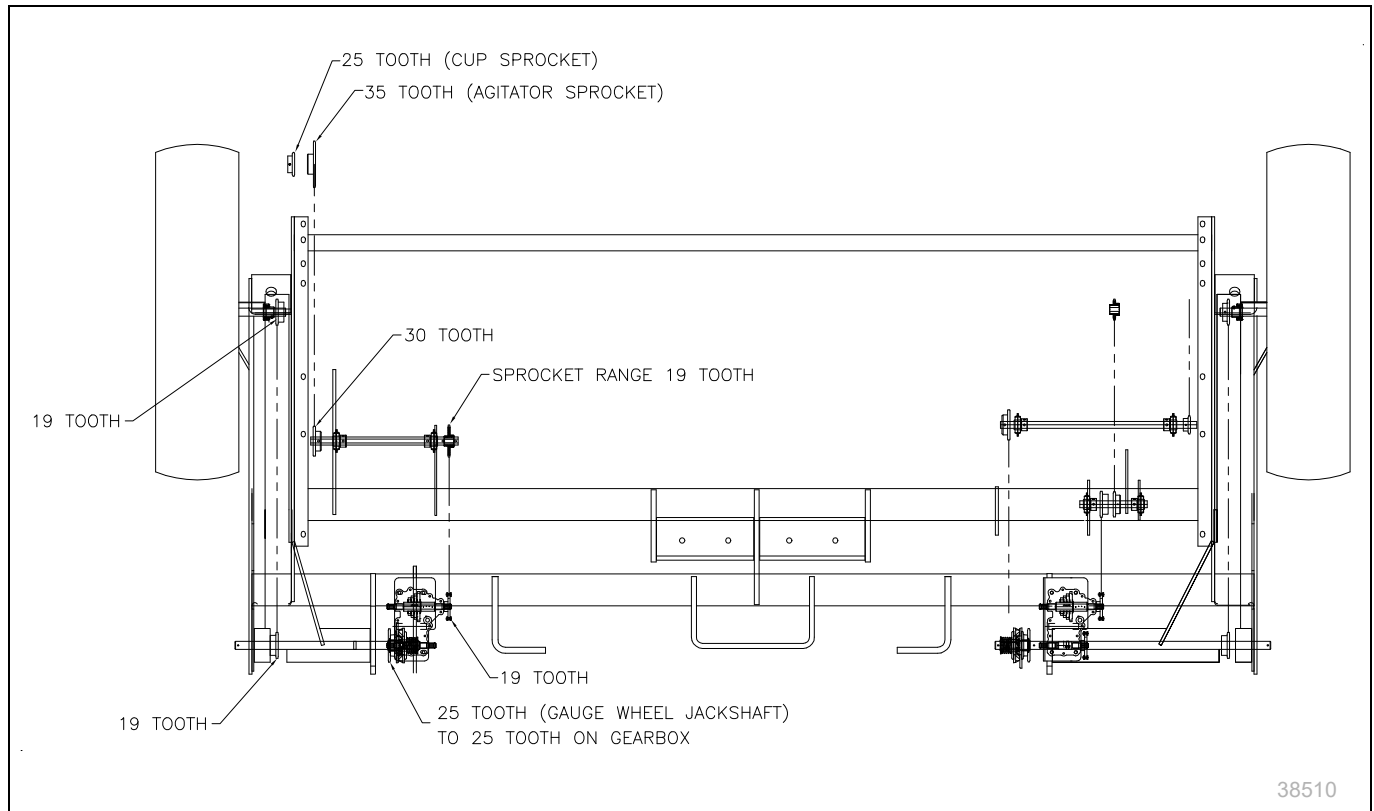

### Small Grass Seeds

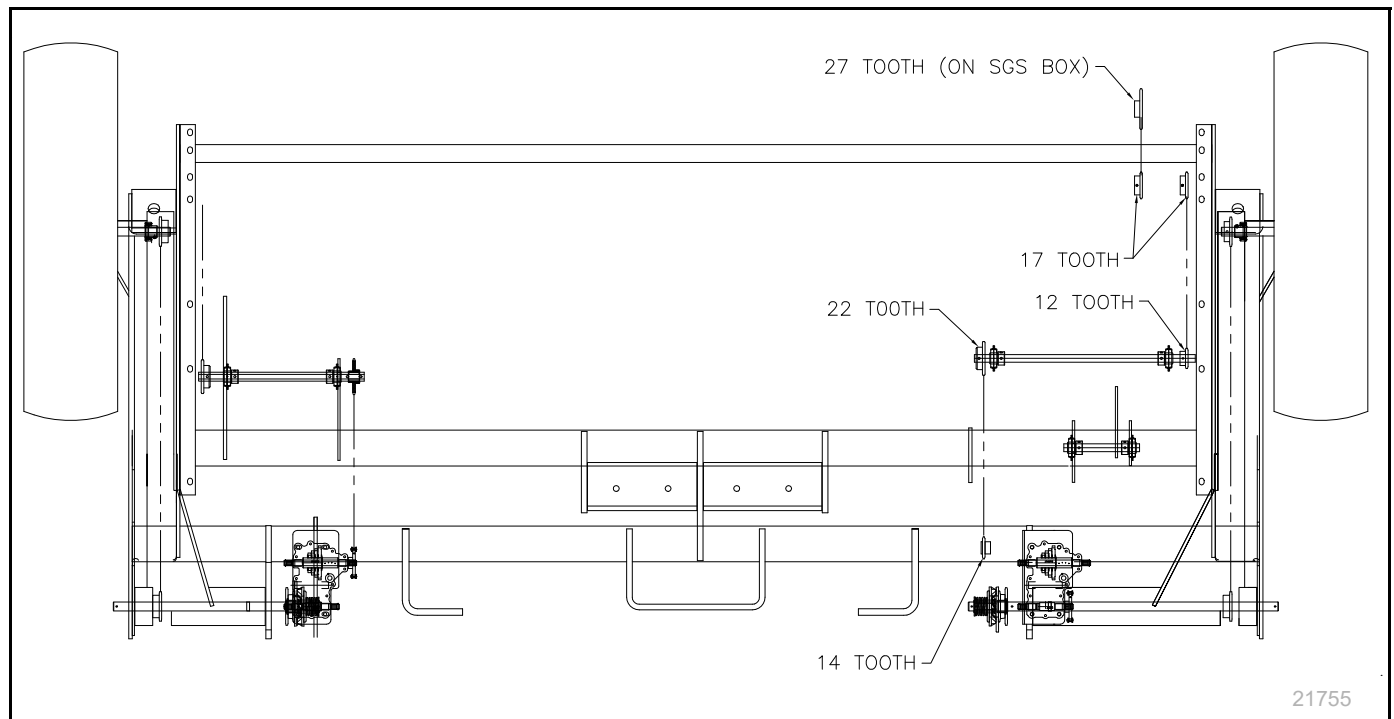

### Native Grass

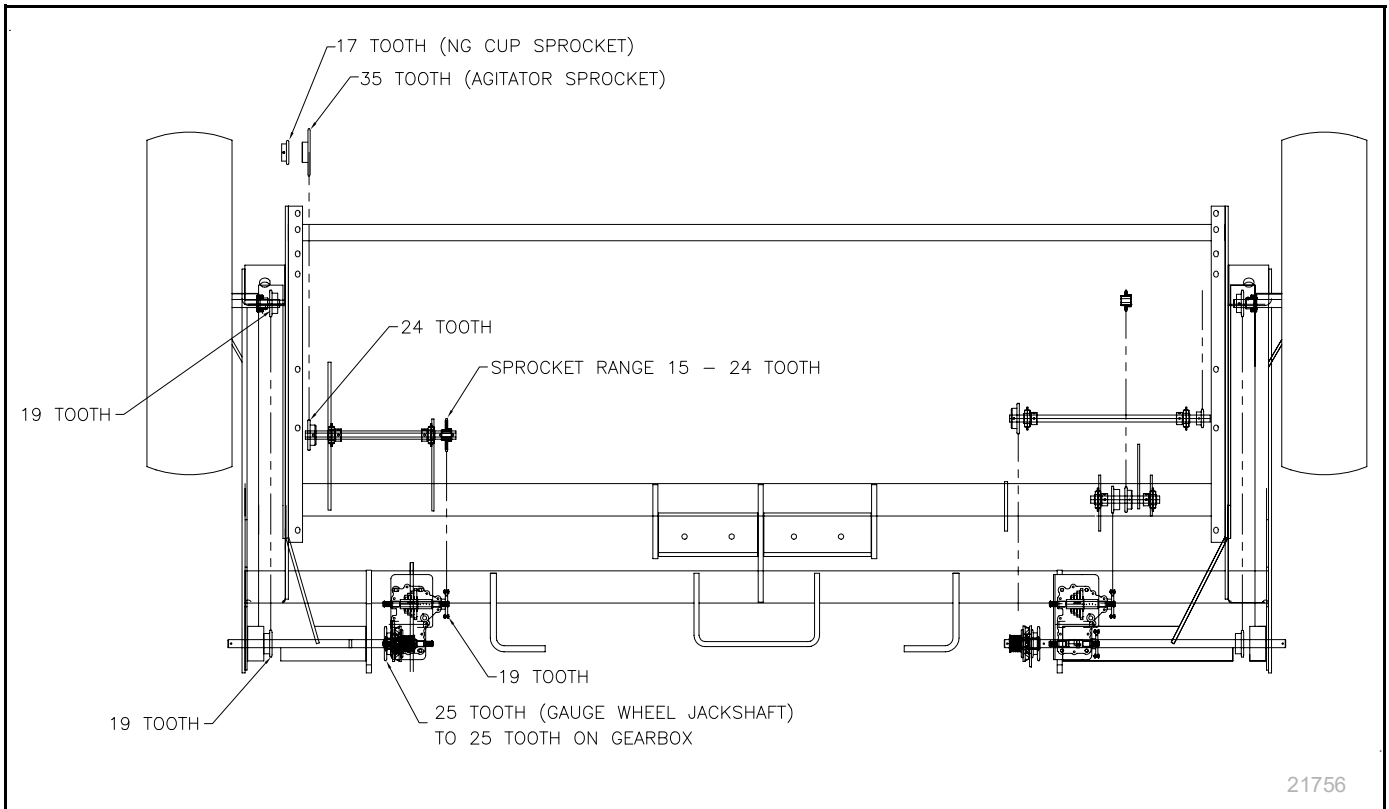

### Fertilizer

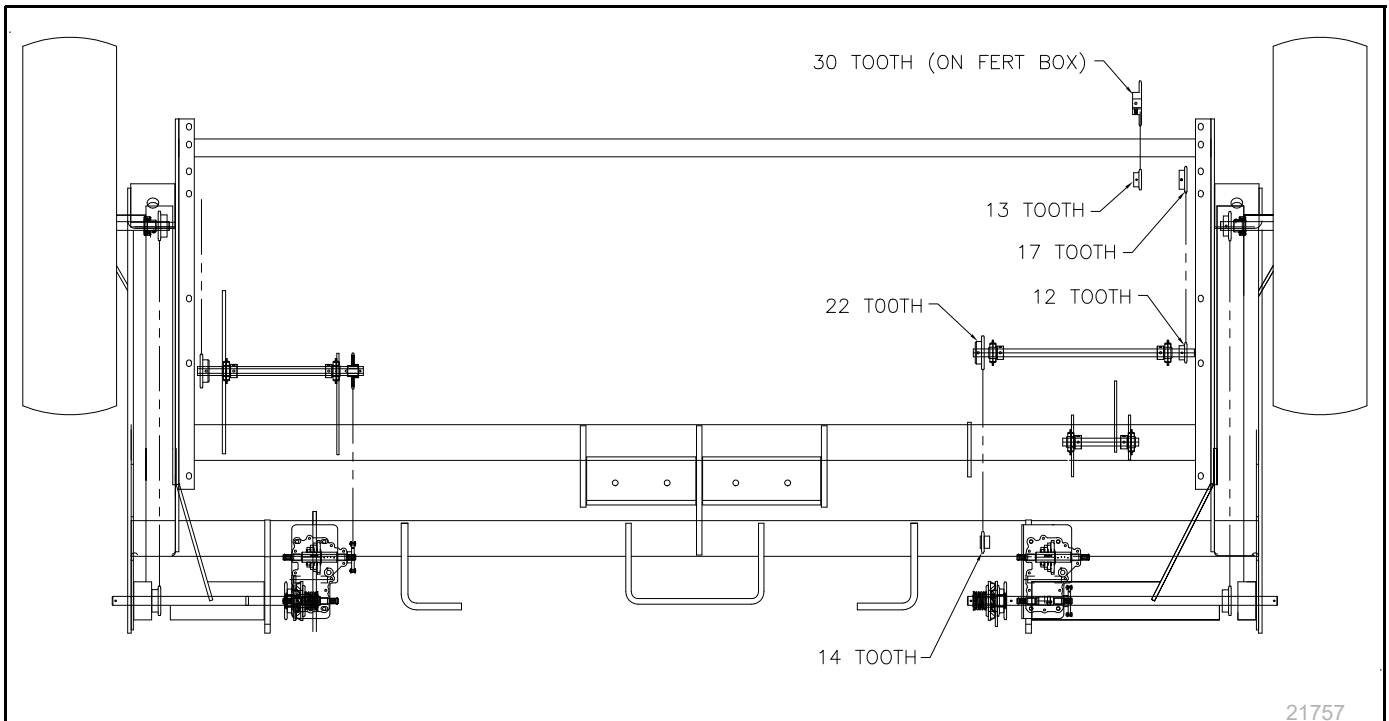



### Fertilizer with Small Grass Seeds Box

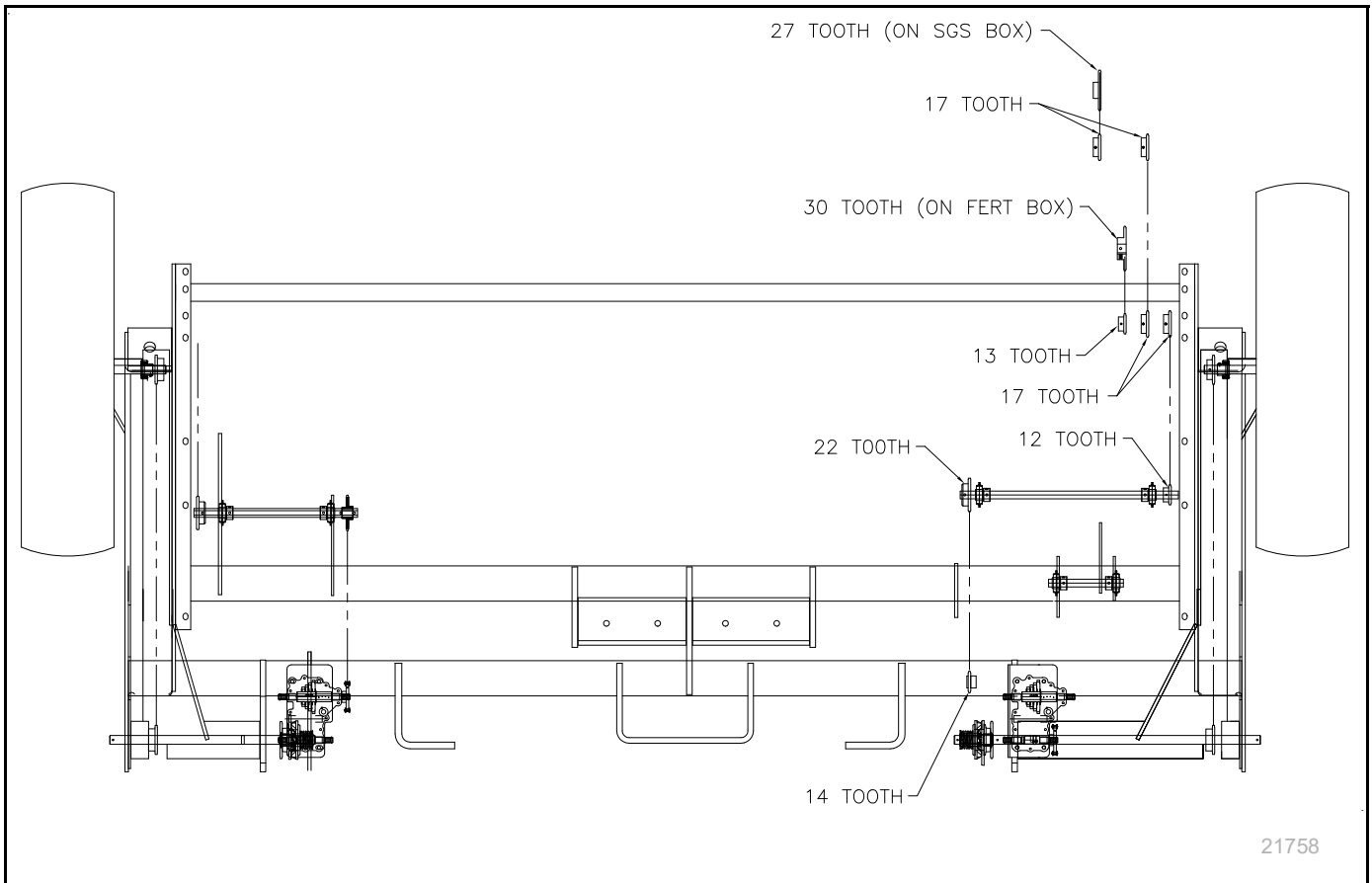



## WARRANTY

Great Plains (a division of Great Plains Manufacturing, Inc.) warrants to the original purchaser that this Great Plains machine will be free from defects in material and workmanship for a period of one year (Parts & Labor) from the first use date when used as intended for personal use; ninety days for custom/commercial or rental use.

Second year limited warranty covers Parts ONLY (personal usage only, excluding labor and wear items). This warranty is limited to the replacement of any defective part by Great Plains. Great Plains reserves the right to inspect any equipment or part which are claimed to have been defective in material or workmanship.

The following items and/or conditions are **NOT COVERED UNDER WARRANTY:** Failures resulting from the abuse or misuse of the equipment, failures occurring as a result of accidental damage or Force Majeure, failures resulting from alterations or modifications, failures caused by lack of normal maintenance as outlined in the operator's manual, repairs made by non-authorized personnel, items replaced or repaired due to normal wear (such as wear items and ground-engaging components including, but not limited to, disc blades, chisel points, tires, bushings, and scrapers), repeat repair due to improper diagnosis or improper repair by the dealer, temporary repairs, service call and /or mileage to and from customer location, overtime premium, or unit hauling expenses. The warranty may be voided if the unit is towed at speeds in excess of 20 miles per hour (32 kilometers per hour), or failures occurring from soils with rocks, stumps, or other obstructions.

Great Plains reserves the right to make changes in materials or design of the product at any time without notice. The warranty shall not be interpreted to render Great Plains liable for damages of any kind, direct or consequential or contingent to property. Furthermore, Great Plains shall not be liable for damages resulting from any cause beyond its control. This warranty does not extend to crop loss, losses caused by planting or harvest delays or any expense or loss of labor, supplies, rental machinery, or for any other reason.

**No other warranty of any kind whatsoever expressed or implied, is made with respect to this sale; and all implied warranties of merchantability and fitness for a particular purpose which exceed the obligations set forth in this written warranty are hereby disclaimed and excluded from this sale.**

This warranty is not valid unless registered by a certified Great Plains dealer.

Effective July 15, 2020

©Great Plains Manufacturing Inc., 2004-GPSV





U

URLs, tires ..... 39

W

WARNING, defined ..... 1

warranty ..... 39

welding ..... 4

Numerics

20 mph ..... 3

3P1006NT ..... 11

30 kph ..... 3

313-521M, manual ..... 11

313-521P, manual ..... 11

313-526B, manual ..... 11

525, Loctite ..... 35

788067, gear lube ..... 35

818-055C, reflector ..... 5

818-578C, high pressure hazard ..... 9

838-265C, reflector ..... 6

838-266C, reflector ..... 5, 6





**Great Plains, Mfg.**  
1525 E. North St.  
P.O. Box 5060  
Salina, KS 67402